

# Double-Well Chaos Circuit

Ian Fritz, April 2007

This circuit produces chaotic oscillations in response to a periodic driving signal. It is an electronic realization of the textbook driven-double-potential-well problem.

Schematic:

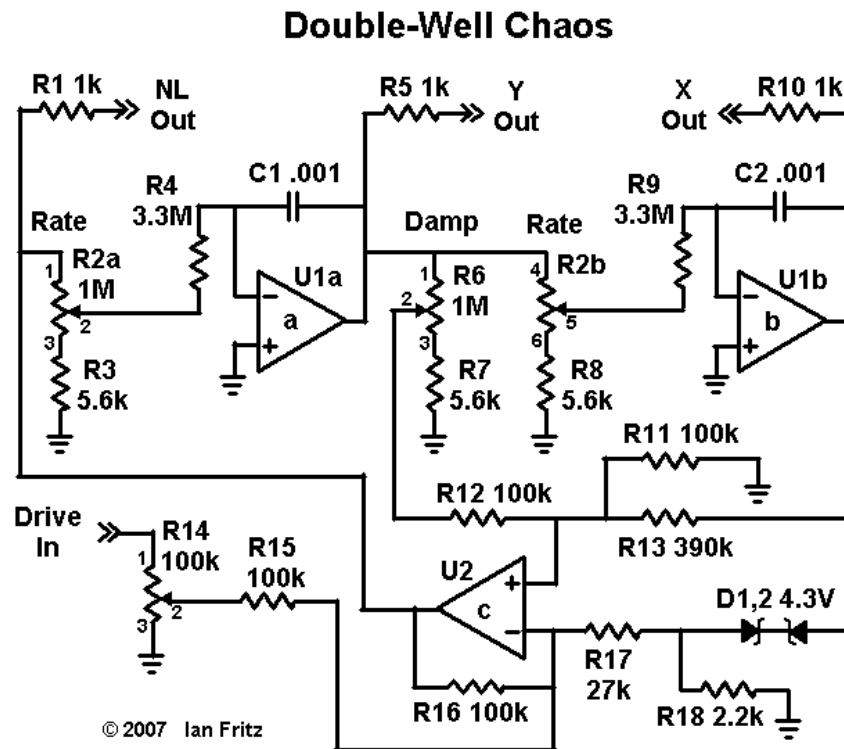

Component List:

U1	TL072 or similar
U2	TL071 or similar
R1, R5, R10	1 kOhm metal film
R2	Dual 1 MOhm pot
R3, R7, R8	5.6 kOhm metal film
R4, R9	3.3 MOhm metal film
R6	1 MOhm pot
R11, R12, R15, R16	100 kOhm metal film
R13	390 kOhm metal film
R14	100 kOhm pot
R17	27 kOhm metal film
R18	2.2 kOhm metal film
C1, C2	1 nF polystyrene or mica
C3, C4	2.2 mF electrolytic bypass (not on schematic)
C5, C6	.022 mF ceramic bypass (not on schematic)
D1, D2	1N749 or other 4.3 V Zener

# Circuit Board:

The board is double sided with overall dimensions of 2.0" x 3.5". The mounting holes are spaced by 1.74" and 3.24". Component placement is indicated on the following drawing:

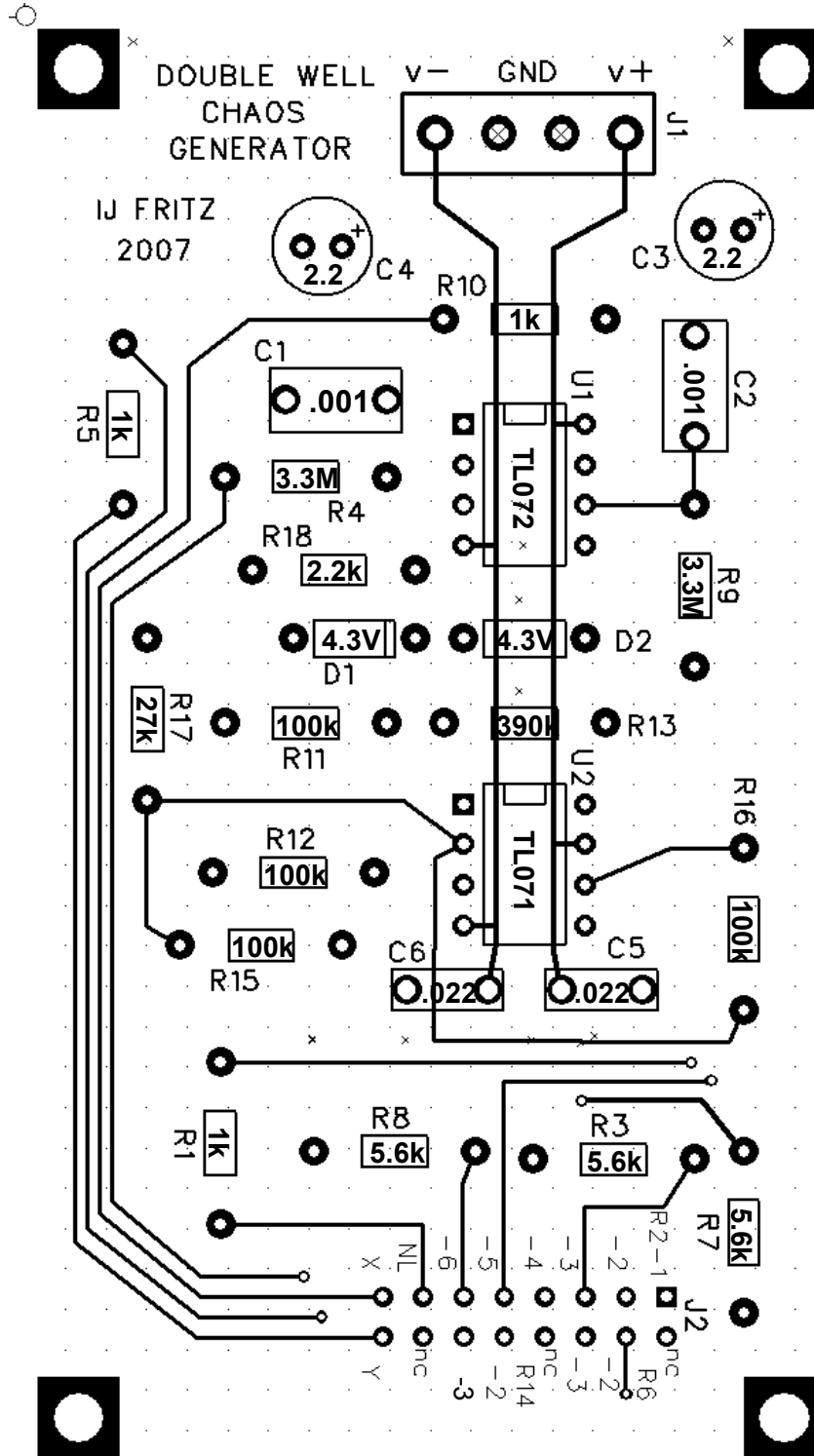

## Notes:

- 1.) There are no critical requirements for the power-supply voltages. The circuit was developed with  $\pm 12$  V supplies, but  $\pm 15$  V should work fine also.
- 2.) Two connections in the circuit diagram are to be made on the front panel. These are (1) the connection from the Drive In connector to R14 (terminal 1) and (2) the connection between the top ends of R2b and R6 (terminals 4 and 1, respectively).
- 3.) The pattern of the chaotic signal changes rapidly with the circuit's drive and damping parameters, as well as with the frequency of the driving signal. Thus it is strongly recommended that fine adjustment of at least some of these parameters be provided for. This can be done either with multi-turn potentiometers or with added fine-tuning controls. For the Drive input, a 5 kOhm pot could be added in series with R14. For the Damping control a 50 kOhm potentiometer in series with R6 would be useful. These may be wired in place on the front panel, without any need to connect to the circuit board.
- 4.) Standard textbooks on nonlinear dynamics and chaos theory can be consulted for the mathematical details of how chaos develops in this system. The following reference is a short text, half of which is devoted to the present system:  
W. Szemplinska-Stupnicka, "CHAOS Bifurcations and Fractals Around Us", World Scientific (2003).
- 5.) More details on the design of chaos circuits as related to mathematical systems of differential equations along with other examples of chaotic circuits are posted on my web site:  
[home.comcast.net/~ijfritz/ch\\_over.htm](http://home.comcast.net/~ijfritz/ch_over.htm)  
The present system is discussed under the title "EZ Chaos":  
[home.comcast.net/~ijfritz/ch\\_cir1.htm](http://home.comcast.net/~ijfritz/ch_cir1.htm)
- 6.) Many web resources on chaos theory, circuits and musical applications are available and easily found through standard search engines.