

Control Of An High Performance 3 DOF Linear Direct Drive Operating With Submicron Precision

Bernhard Sprenger, Oliver Binzel

Swiss Federal Institute of Technology Zurich (ETHZ) • Institute of Robotics
8092 Zurich, Switzerland • Email: sprenger@ifr.mavt.ethz.ch

Roland Siegwart

Swiss Federal Institute of Technology Lausanne (EPFL) • Institute of Robotics Systems
1015 Lausanne, Switzerland • Email: roland.siegwart@epfl.ch

ABSTRACT

Developments in microelectronics, micromechanics and microelectromechanical systems (e.g. micromotors, microsensors) require significant improvements in manufacturing tools for mass productions. Especially the assembling tools have to become faster and more precise.

Many assembly devices use *XY* stages driven by DC servomotors with ball screws or parallel structures; others use linear drives with traditional ball bearings. Only a few devices use linear drives together with air bearings, but always together with an angular guide for *X* and *Y* direction. The novel approach presented in this paper is based on linear drives together with a planar air bearing. In contrast to other stages, it doesn't need any angular guides. This reduces the moved mass and leads to higher accelerations. It consists of an arrangement of three respectively four identical moving-coils attached to a slide, which is suspended by a planar air bearing. This novel configuration allows a large workspace and high accelerations. In the realized experimental setup the workspace is limited to 60 x 60 mm², due to the used sensor system. Furthermore, the maximal possible acceleration is limited to 3 g, due to the used power amplifiers. The attainable performance has been proved in the whole workspace by 30 mm translational strokes on sinusoidal trajectories within 0.09 seconds together with a transient overshoot smaller than 900 nm. For slower movements or smaller strokes the transient overshoot reduces down below 100 nm. The stationary positioning noise can be smaller than 30 nm, depending on the stiffness of the used control structure.

This paper gives an overview of the system, focuses on the controller design and shows the achieved performance.

INTRODUCTION

The need for high speed and high precision positioning systems is increasing in many fields of technology, such as microelectronics [1], micromechanics and microelectromechanical systems. For mass production, the assembling/mounting tools have to achieve high precision and have to work with high speed or/and highly parallel.

There are many concepts to build high speed or high precision manipulators, but only a few of them can serve to obtain high speed together with high precision:

- Ball screw drives obtain high precision, but high speed can not be reached because of its large inertia and high friction.
- Impact drives [2] and inchworms achieve high resolution over a large working area, but only with low speed. Their main fields of application are the manipulation of small objects underneath microscopes (e.g. the manipulation of cells in science of medicine or biology) and near field microscopy.
- Fast parallel drives, similar to the Delta-Robot [3], have the advantage, that their motors are fixed and don't have to be moved. This reduces the moved mass and allows to achieve high acceleration. They use ball bearings for the joints, which have radial run-out of several μm . The inaccuracy is growing with each joint of the robot. Other problems are the low stiffness of these structures, the friction in the joints and the difficult kinematics and dynamics. All these effects make it difficult to achieve high precision together with large acceleration. This may change with direct visual feedback, but the speed of image processing will still be a limiting factor.
- Steel cables or steel belts as transmission elements allow the construction of high performance manipula-

tors [4]. Their main advantage is, that their motors are fixed and don't have to be moved, which leads to minimal inertia of all moving parts. The attainable resolution is limited due to their vibrational properties, their complex deflection of cables/belts and their friction.

- Linear drives achieve high performance and good resolution, but their combination for multiple degrees of freedom (dof) is difficult to realize. They are often arranged to parallel structures by the use of angular guides [5]. The friction can be eliminated by air bearings, leading to an enhanced precision [6]. Unfortunately air bearings have the nasty behavior that their stiffness varies in relation to the applied load. Because the air bearings used in angular guides are exposed to tensile and compression stress, the natural frequencies of the complete system varies in a nonlinear manner. Therefore these varying natural frequencies limit the attainable dynamics. Further disadvantages of these solutions are their complex designs (e.g. 3 air bearings) and the large mass resulting from the angular guides.
- Planar Magnetic Levitators [7] are promising but require a more complex system design, resulting in higher system costs.

A novel type of a 3 dof linear drive is presented in this paper. This approach consists of three, respectively four, identical moving coils attached to a slide, which glides on a granite plate and is suspended by one planar air-bearing. In contrast to other stages, it doesn't need any angular guide. This elimination of angular guides increases the stiffness and controllability of the structure and reduces the moved mass, leading to higher performance. It also simplifies the mechanical construction. The current experimental setup has a workspace of $60 \times 60 \text{ mm}^2$. The system is designed for accelerations up to 10 g acceleration, but at the moment the maximal acceleration is limited to 3 g due to the used power amplifiers. The sensor system delivers a resolution of 4 nm.

The electromechanical design of the system was optimized by FEM-simulation and has been published in [8]. Therefore the paper gives only a short overview of the system, focuses on the control design and proofs the performance of this solution.

SYSTEM OVERVIEW

Basic elements of this 3 dof linear-drive are its actuators (fig. 1), based on moving coils. Each of them consists of a merged arrangement of two traditional voice coils [9][10][11]. In the field of fast and precise positioning the main advantage of moving coils is that only the light coil moves whereas the heavy stator/core is

fixed. In addition, the use of air bearings results in a frictionless design. This frictionless actuation and the linear current-force relation ease the controller design and increase the attainable precision.

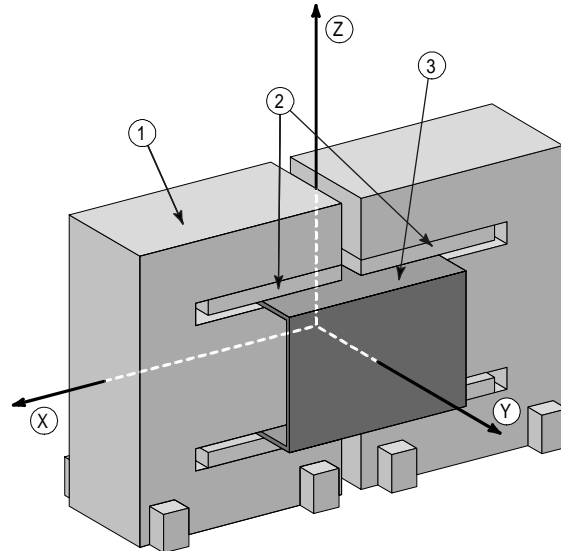

FIGURE 1: Voice-Coil Type Actuator (1-Core/Stator, 2-Magnet, 3-Moving Coil)

The arrangement of bearings is done by one planar air bearing, which permits free movement in the XY -plain, whereas movements in Z -direction and rotations around X -/ Y -axis are prevented. Therefore a minimum of three actuators are necessary to control these 3 dof. The advantage of uncoupled XY -measurement systems leads towards a rectangular configuration with three actuators. In order to avoid high torsion stress in the system and to increase its controllability and performance, a 4th actuator can be added, resulting in a more symmetrical, but redundantly actuated system (fig. 2). The redundancy in actuation can easily be treated by the controller.

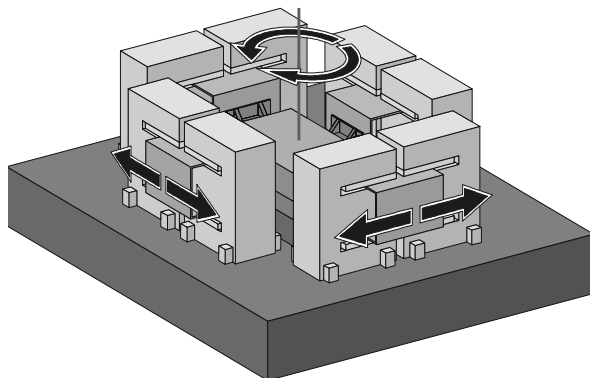

FIGURE 2: Four Actuator Configuration

However, the realized setup is the configuration with three actuators, which allows the mounting of a tool at the free side and is shown in fig. 3. Furthermore, it

increases the accessibility to the sensor system for calibrating purposes. The cross section of the system is shown in fig. 4. It consists of three identical moving coils attached to the slide, which glides on a granite plate suspended by the planar air-bearing. This bearing consists of pressure and vacuum zones, delivering high stiffness.

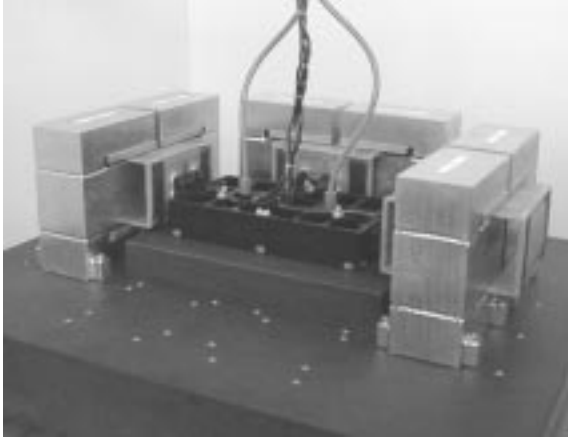

FIGURE 3: Experimental Setup

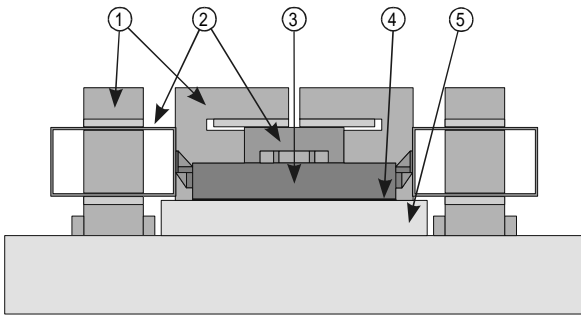

FIGURE 4: Cross Section
(1-Cores/Stators, 2-Moving Coils, 3-Slide,
4-Air Bearing, 5-Granite Plate)

Because of the used sensor system, which allows only small rotational displacements of less than ± 1.5 mrad ($\pm 0.1^\circ$), the set point of the rotational angle, used by the controller, is kept at a constant value of 0° . As a result, the controlled system is limited to free positioning in X - and Y -axis (2 dof), whereas the controller has to deal with 3 dof.

In order to achieve optimal performance and to decouple the system from the floor it would be best to mount the granite plate on top of an huge concrete block, but this solution would only be realizable for laboratory use and not for a production line. Therefore the granite plate is fixed to a bench by rubber mountings. The disadvantage of these mountings are their nonlinear damping, which decreases the performance of the complete system.

CONTROL SYSTEM

Sensor System

Due to the lack of a sensor system delivering both the XY -position as well as the rotational angle with the demanded accuracy, a combination of 2 commercially available two-coordinate sensor systems is used instead. These sensor systems are incremental two-coordinate grid plate encoders from *Heidenhain*, each delivering an accurate XY -position with a resolution of 4 nm. The rotational angle around the Z -axis is obtained from these two positions together with the distance between the two sensor systems, resulting in a rotational resolution of about 1 μ rad.

Due to their physical principle, these sensors allow only a tiny rotational displacement (around the Z -axis) between the sensor head and the grid plate. The dependency between the amplitude of the delivered encoder signals (sinusoidal form) and the rotational displacement around the Z -axis is shown by fig. 5.

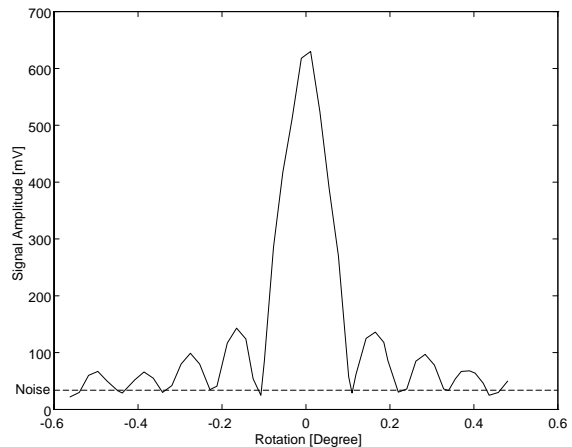

FIGURE 5: Amplitude-Rotation Sensitivity

This amplitude-rotation relation is quite similar to a sinc^2 -function. Its generation can be explained by the moiré effect between the grid plate and the reference grid due to rotational displacement. Because of the zeros in this function, the usability of these sensor systems is limited to rotational displacements of less than ± 1.5 mrad ($\pm 0.1^\circ$). This restricted working range implicates, that the set point of the rotational angle, used by the controller, is kept at a constant value of 0° . Therefore the controlled system allows only free positioning in x - and y -axis (2 dof), whereas the controller has to deal with 3 dof.

The amplitude information is easily extracted out of the 90° phase shift encoder signals ($\cos^2 + \sin^2 = 1$) and therefore it will also be used by the controller to toggle the emergency stop, when the slide leaves the allowed rotational range.

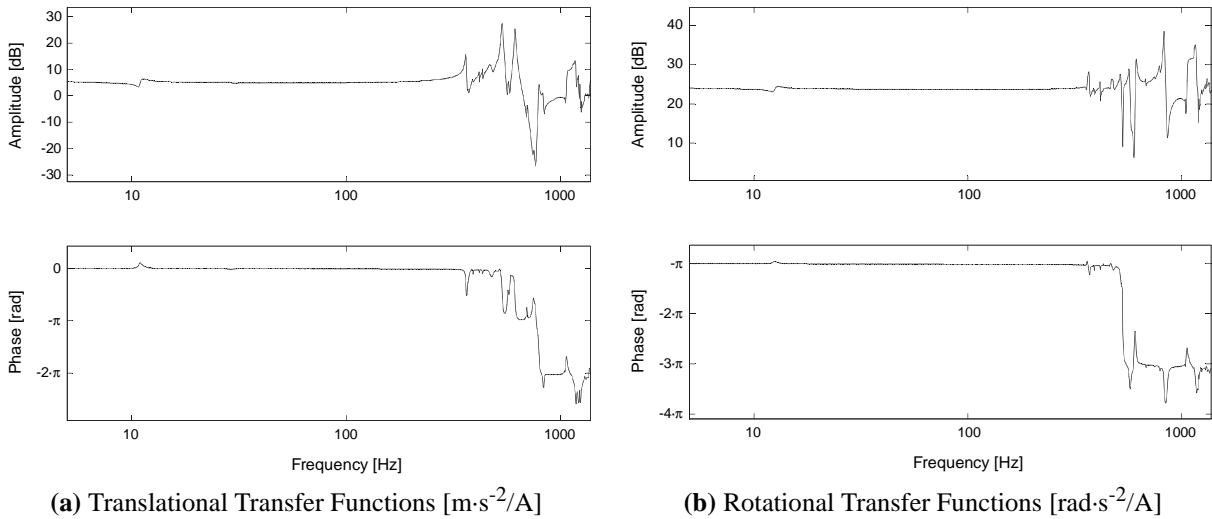

FIGURE 6: Typical Transfer Function of one Voice Coil

Plant Modeling

In order to achieve optimal performance it is necessary to have a good model of the plant. There are mainly three possibilities to model the system. First the slide and coils can be modeled together as one rigid body. The parameters of this model can be estimated on-line by the use of an adaptation law [12]. Secondly the slide and coils can be modeled as rigid bodies fixed together with flexible joints. This leads to a huge non-linear model, resulting in difficulties to identify its parameters. The third possibility is to approximate the system as a linear state-space model, which can be obtained from the transfer functions.

The realization described in this paper uses a combination between the first and third approach. The rigid body model is used in the feed-forward path of the controller, whereas the state-space representation is used for the state-space controller and its Kalman estimator. The typical translational and rotational acceleration-current transfer function of one actuator is shown in fig. 6. The appropriate translational and rotational position-current transfer functions are calculated

by double integration. They are approximated by polynomials in the frequency space and composed into a MIMO¹-System with three inputs (coil-currents u_1, u_2, u_3) and three outputs (x, y, φ), leading to a state-space representation of 40th order. Particularly the modeling of the low frequency poles and zeros at about 11 Hz is significant for the reachable precision. These pole- and zero-pairs arise from the elasticity of the rubber mountings between the granite plate and the bench. These rubber mountings allow a displacement of the grant plate of about 1 mm when applying a force of about 200 N and they have a nonlinear characteristic.

Control Structure

As mentioned above the controller (fig. 7) consists of a feed-forward path, using the rigid body model, and a linear state-space controller together with a linear Kalman estimator (observer). The state-space part of the controller was designed as a multivariable linear quadratic regulator (LQR) and the estimator as a multivariable linear quadratic gaussian estimator (LQG).

1. MIMO = Multiple Input Multiple Output

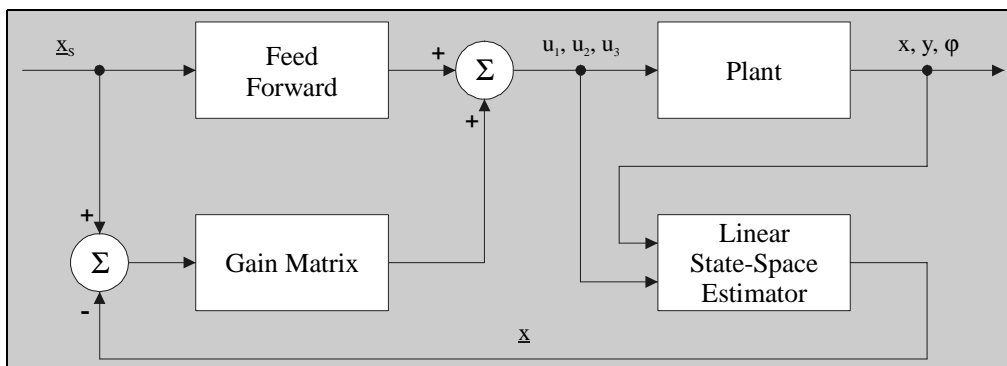

FIGURE 7: Linear State-Space Controller with Feed-Forward Path

Due to the inaccuracy of the state-space representation, which results from the modeling of a nonlinear system as a linear state-space model, the design of the controller leads towards a balancing act between the resulting transient and the resulting stationary behavior. The more the transient behavior (overshoot and control accuracy) is weighted in the design process, the further some closed-loop poles move towards the right half plane in the pole-zero map, resulting in less robustness and in increased stationary positioning noise or even in instability. If the transient behavior is weighted less, the robustness increases, the stationary positioning noise decreases, but together with an increased transient overshoot and a larger stationary offset.

The reached performance of this control system is shown in fig. 8 for fast movements and in fig. 9 for slow movements. Fig. 8 shows a 30 mm translational stroke on a sinusoidal trajectory within 0.09 seconds, reaching an acceleration of $25 \text{ m}\cdot\text{s}^{-2}$. The transient overshoot is smaller than 900 nm. The decaying oscillation of about 11 Hz derives from the inexact modeling of the rubber mountings, due to their nonlinearities as mentioned before. The perturbed motion of the other axe during this transition is less than 600 nm. Fig. 9 shows a 30 mm translational stroke on a sinusoidal trajectory within 0.5 seconds and a transient overshoot smaller than 100 nm. Both figures show a stationary behavior with a positioning noise smaller than 60 nm around an offset of about 50 nm.

If for the controller design the transient behavior is slightly less weighted, the stationary positioning noise is reduced below an amplitude of 30 nm (fig. 10), but the transient overshoot for fast movements (30 mm in 90 ms) is enlarged to about $1.1 \mu\text{m}$. If even less dynamics is needed, it is possible to reduce the positioning noise down towards 10 nm. It's also possible to combine these behaviors by automatically switching between the different gain matrixes, depending on the actual movement.

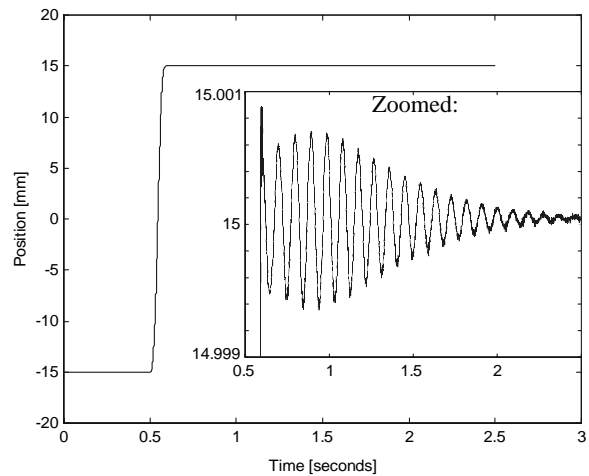

FIGURE 8: Fast Movements (30 mm in 90 ms)

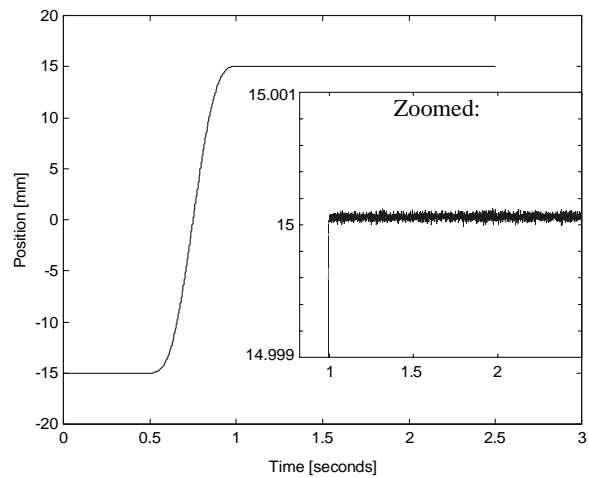

FIGURE 9: Slow Movements (30 mm in 500 ms)

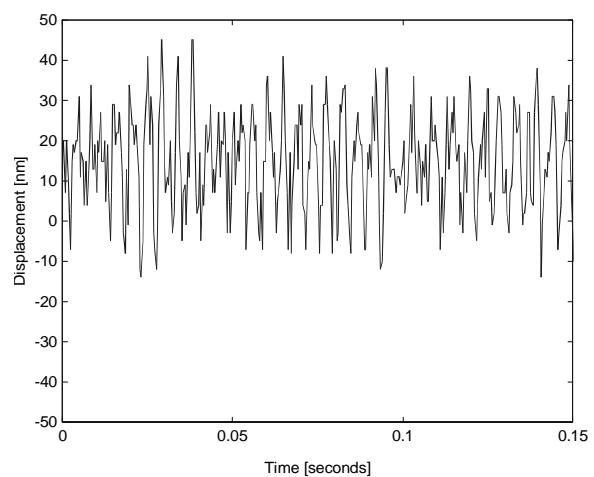

FIGURE 10: Stationary Behavior

CONCLUSIONS

A new design of a linear drive has been introduced in this paper, which is based on traditional voice coil actuators. This drive is a wear-free, maintenance-free and frictionless design because of its air bearing. Therefore it's well fitted for clean room applications, especially for the semiconductor manufacturing, and for all systems requiring 24 h continuous production with high throughput. The current experimental setup has a workspace of $60 \times 60 \text{ mm}^2$ together with a sensor resolution of 4 nm. Its performance has been shown by 30 mm translational strokes on sinusoidal trajectories within 0.09 seconds together with a transient overshoot smaller than 900 nm. For slower movements or smaller strokes the transient overshoot reduces down below 100 nm. The stationary positioning noise is smaller than 30 nm, depending on the stiffness of the used control structure.

The performance of the system can be increased, if acceleration sensors are included. First preliminary results show already, that, if only the acceleration of the granite plate is measured and used in the feed forward path of the controller, the transient overshoot for fast movements (30 mm in 0.09 s) reduces already down below 750 nm (instead of 900 nm). Therefore it should be possible to reduce this overshoot even more, if acceleration sensors are used by the state-space controller. Another possibility to reduce the overshoot is the introduction of some damping windings (short-circuited windings) in the voice coil actuators, resulting in a linear damping, which eases the controller design and its performance.

REFERENCES

- [1] W. Beckenbaugh, "Manufacturing Implications of Ultra High Speed Packaging and Interconnect Design", *Fourth IEEE/CHMT European International Electronic Manufacturing Technology Symposium Proceedings*, pp. 108-111, 1988.
- [2] W. Zesch, R. Büchi, A. Codourey and R. Siegwart, "Inertial Drives for Micro- and Nanorobots: Two Novel Mechanisms", *SPIE Microrobotics and Micromechanical Systems*, Philadelphia, USA, pp. 80-88, October 1995.
- [3] R. Clavel, "DELTA, a Fast Robot with Parallel Geometry", *Int. Symp. on Industrial Robots (ISIR)*, pp. 91-100, 1988.
- [4] H. Fässler, H. A. Beyer and J. Wen, "Robot Ping Pong Player. Optimized Mechanics, High Performance 3D Vision, and Intelligent Sensor Control", *Robotersysteme*, Vol. 6, No. 3, pp. 161-170, 1990.
- [5] O. Masamitsu, H. Toyomi and W. Mitsuhiro, "High Speed and High Accuracy XY-Stage for Electronic Assembly", *Fourth IEEE/CHMT European International Electronic Manufacturing Technology Symposium, Proceedings*, pp. 104-107, 1988.
- [6] C. Meisser, H. Eggenschwiler and W. Nehls, "Einrichtung zur Durchführung der Zustellbewegung eines Arbeitsorgans zu einer Arbeitsstation", *European Patent Application No. 0317787B1*, ESEC SA, 1988.
- [7] W. Kim and D. Trumper, "Active Multivariable Optimal Control of a Planar Magnetic Levitator", *IEEE International Conference on Control Applications*, Hartford, USA, pp. 97-102, October 1997.
- [8] Sprenger B. and Siegwart R., "Novel High Speed 3 DOF Linear Direct Drive Operating With Submicron Precision", *SPIE International Conference of Intelligent Systems & Automated Manufacturing '97*, Pittsburgh, USA, 1997.
- [9] G.W. McLean, "Review of Recent Progress in Linear Motors", *IEE Proceedings Part B v 135*, pp. 380-416, 1988.
- [10] J. Stupak and G. Gogue, "Voice-Coil Actuators: Insight into the Design", *Intelligent Motion*, pp. 241-253, October 1989.
- [11] B. Black, M. Lopez and A. Morcos, "Basics of Voice Coil Actuators", *PCIM*, pp. 44-46, July 1993.
- [12] E. Burdet, B. Sprenger and A. Codourey, "Experiments in Nonlinear Adaptive Control", *IEEE International Conference on Robotics and Automation*, Albuquerque, USA, April 1997.