

CHAPTER 6
SPRING, BELLOW,
FLEXURE, SCREW, AND
BALL DEVICES

FLAT SPRINGS IN MECHANISMS

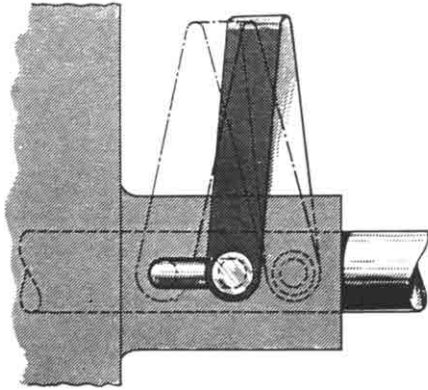

Constant force is approached because of the length of this U-spring. Don't align the studs or the spring will fall.

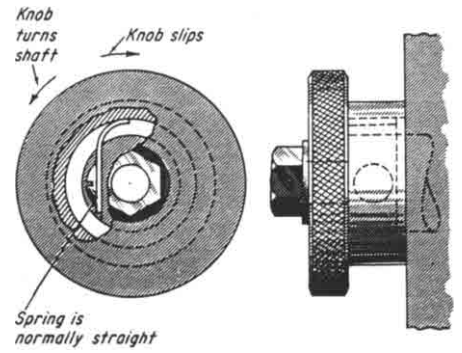
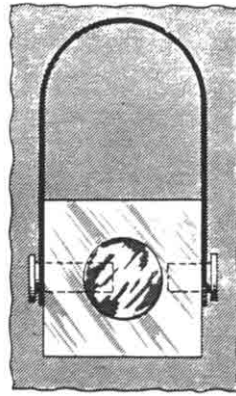

A flat-wire sprag is straight until the knob is assembled: thus tension helps the sprag to grip for one-way clutching.

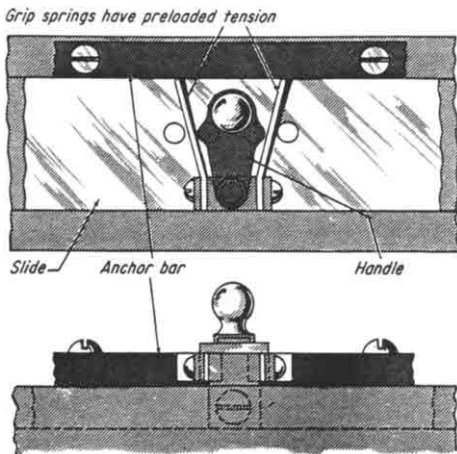

Easy positioning of the slide is possible when the handle pins move a grip spring out of contact with the anchor bar.

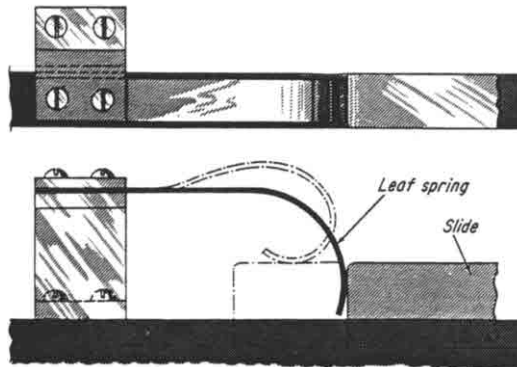

A spring-loaded slide will always return to its original position unless it is pushed until the spring kicks out.

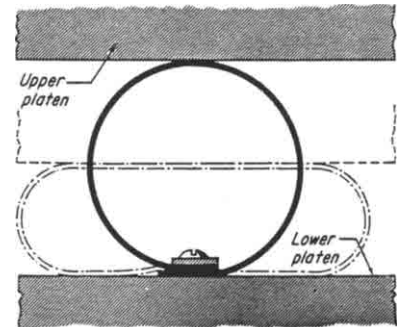

Increasing support area as the load increases on both upper and lower platens is provided by a circular spring.

Nearly constant tension in the spring, as well as the force to activate the slide, is provided by this single coil.

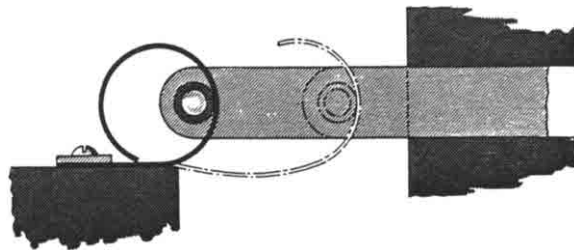

This volute spring lets the shaft be moved closer to the frame, thus allowing maximum axial movement.

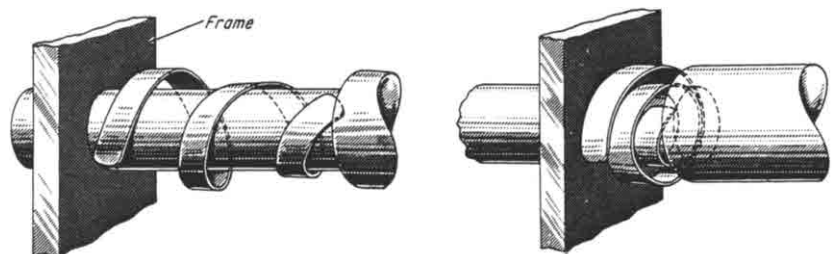

These mechanisms rely on a flat spring for their efficient actions.

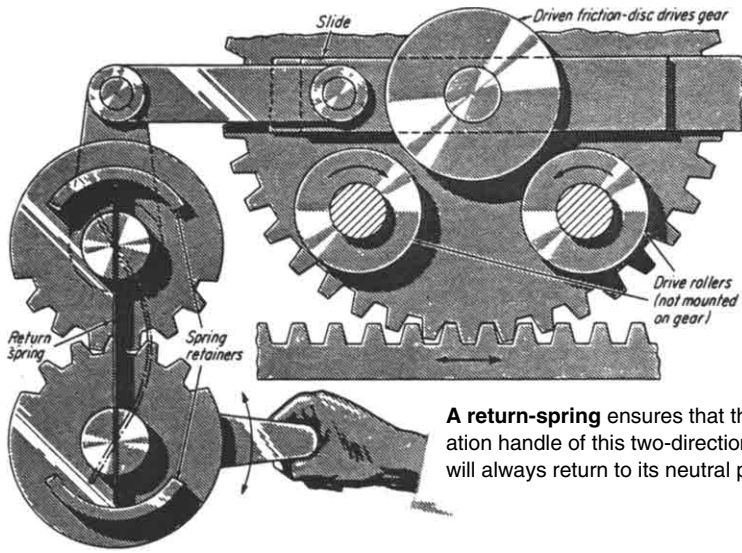

A return-spring ensures that the operation handle of this two-direction drive will always return to its neutral position.

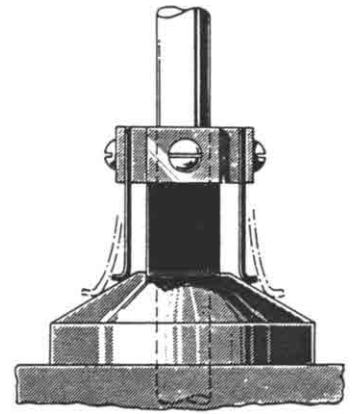

This cushioning device imparts rapid increase of spring tension because of the small pyramid angle. Its rebound is minimum.

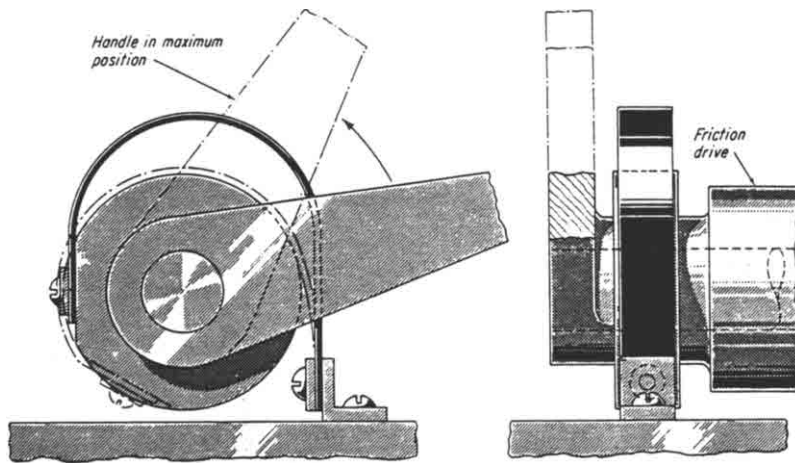

This spring-mounted disk changes its center position as the handle is rotated to move the friction drive. It also acts as a built-in limit stop.

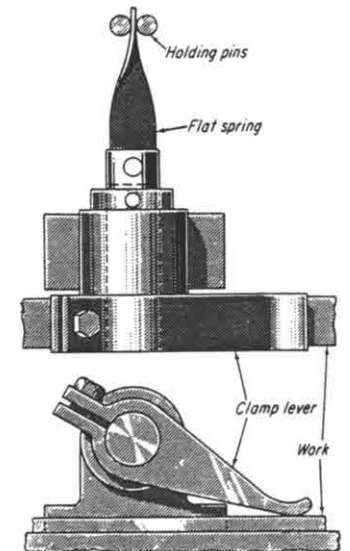

This hold-down clamp has its flat spring assembled with an initial twist to provide a clamping force for thin material.

Indexing is accomplished simply, efficiently, and at low cost by flat-spring arrangement shown here.

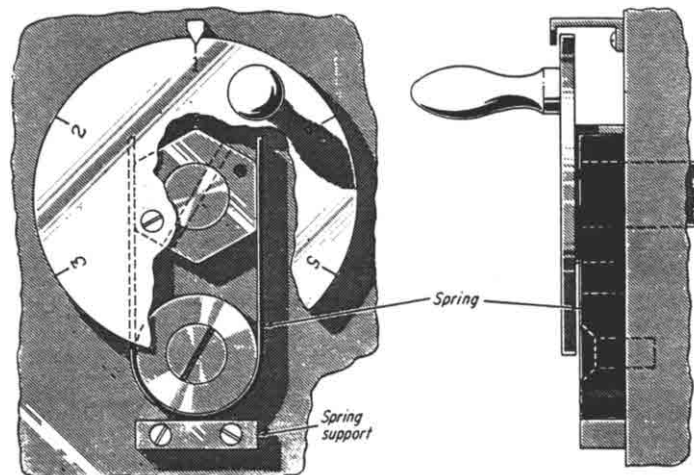

POP-UP SPRINGS GET NEW BACKBONE

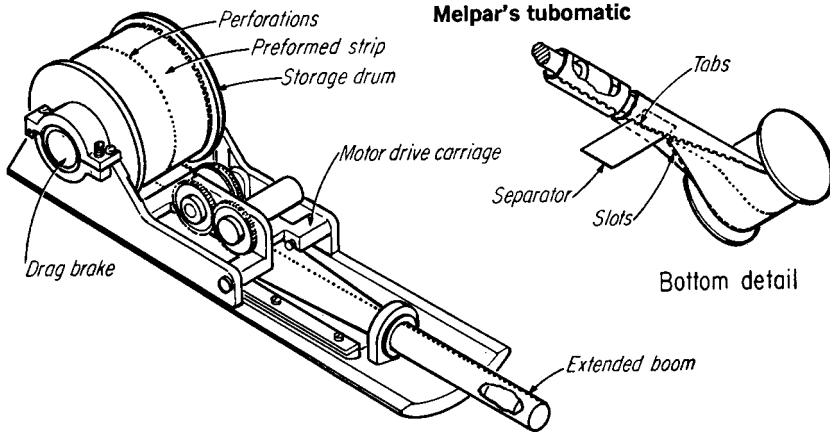

An addition to the family of retractable coil springs, initially popular for use as antennas, holds promise of solving one problem in such applications: lack of torsional and flexural rigidity when extended. A pop-up boom that locks itself into a stiffer tube has been made.

In two previous versions—De Havilland Aircraft's Stem and Hunter Springs's Helix—rigidity was obtained by permitting the material to overlap. In Melpar's design, the strip that unrolls from the drum to form the cylindrical mast has tabs and slots that interlock to produce a strong tube.

Melpar has also added a row of perforations along the center of the strip to aid in accurate control of the spring's length during extension or contraction. This adds to the spring's attractiveness as a positioning device, besides its established uses as antennas for spacecraft and portable equipment and as gravity gradient booms and sensing probes.

Curled by heat. Retractable, prestressed coil springs have been in the technical news for many years, yet most manufacturers have been rather close-mouthed about exactly how they convert a strip of beryllium copper or stainless steel into such a spring.

In its Helix, Hunter induced the prestressing at an angle to the axis of the strip, so the spring uncoils helically; De Havilland and Melpar prestress the material along the axis of the strip.

A prestressing technique was worked out by John J. Park of the NASA Goddard Center. Park found early in his assignment that technical papers were lacking on just how a metal strip can be given a new "memory" that makes it curl longitudinally unless restrained.

Starting from scratch, Park ran a series of experiments using a glass tube, 0.65 in. ID, and strips of beryllium copper alloy, 2 in. wide and 0.002 in. thick. He found it effective to roll the alloy strip lengthwise into the glass tube and then to heat it in a furnace. Test strips were then allowed to cool down to room temperature.

It was shown that the longer the treatment and the hotter the furnace time, the more tightly the strip would curl along its length, producing a smaller tube. For example, a test strip heated at 920° F for 5 min would produce a tube that remained at the 0.65-in. inside diameter of the glass holder; at 770 F, heating for even 15 min produced a tube that would expand to an 0.68-in. diameter.

By proper correlation of time and temperature in the furnace, Park suggested that a continuous tube-forming process could be set up and segments of the completed tube could be cut off at the lengths desired.

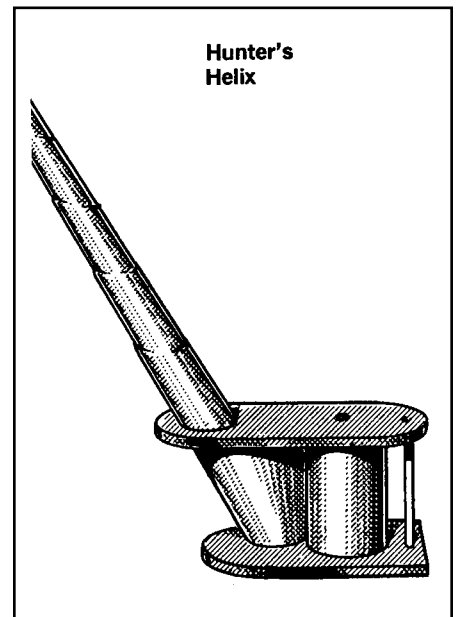
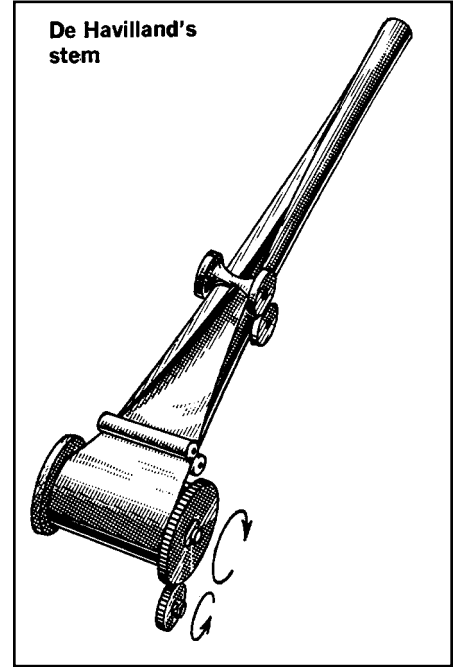
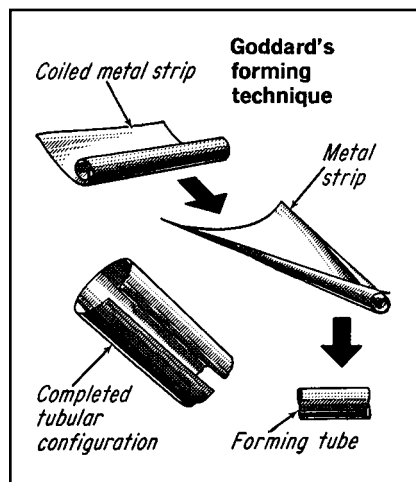

TWELVE WAYS TO PUT SPRINGS TO WORK

Variable-rate arrangements, roller positioning, space saving, and other ingenious ways to get the most from springs.



This setup provides a **variable rate** with a sudden change from a light load to a heavy load by limiting the low-rate extension with a spring.

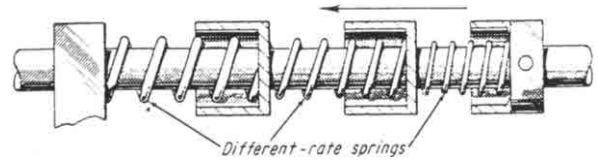

This mechanism provides a **three-step rate** change at predetermined positions. The lighter springs will always compress first, regardless of their position.

This **differential-rate** linkage sets the actuator stroke under light tension at the start, then allows a gradual transition to heavier tension.

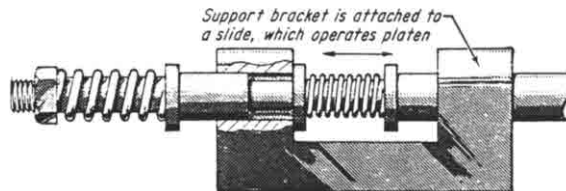
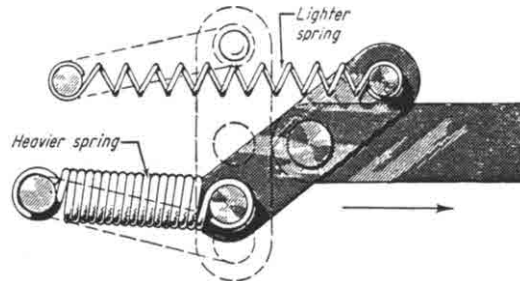

This **compressing mechanism** has a dual rate for double-action compacting. In one direction pressure is high, but in the reverse direction pressure is low.

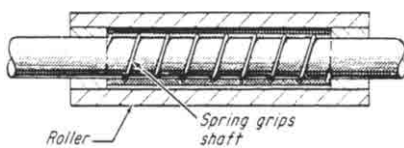

Roller positioning by a tightly wound spring on the shaft is provided by this assembly. The roller will slide under excess end thrust.

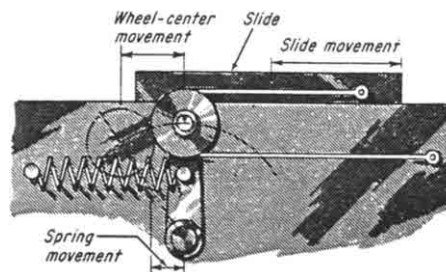

A **short extension** of the spring for a long movement of the slide keeps the tension change between maximum and minimum low.

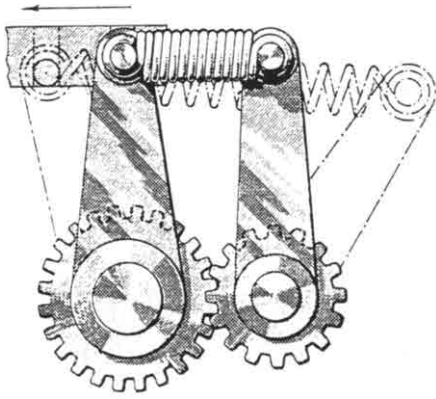

Increased tension for the same movement is gained by providing a movable spring mount and gearing it to the other movable lever.

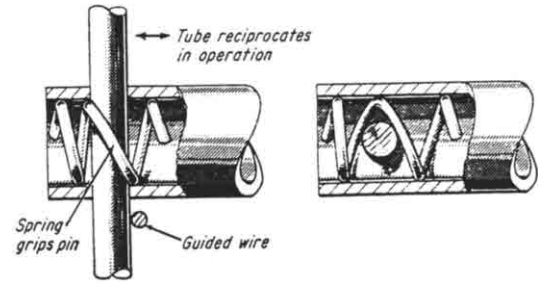

This pin grip is a spring that holds a pin by friction against end movement or rotation, but lets the pin be repositioned without tools.

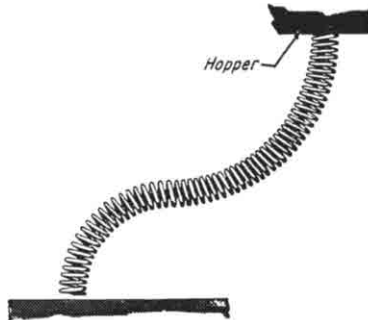

A close-wound spring is attached to a hopper, and it will not buckle when it is used as a movable feed-duct for nongranular material.

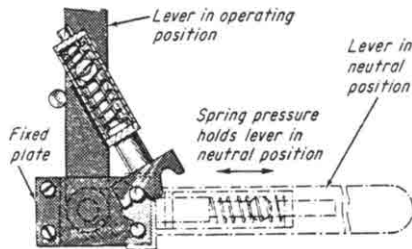

Toggle action here ensures that the gear-shift lever will not inadvertently be thrown past its neutral position.

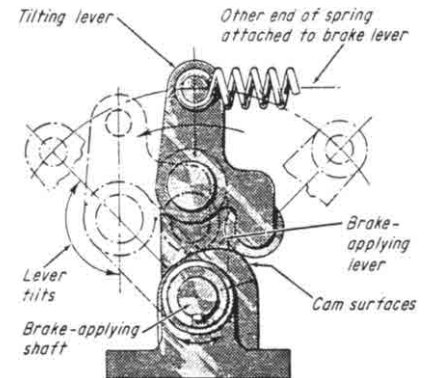

Tension varies at a different rate when the brake-applying lever reaches the position shown. The rate is reduced when the tilting lever tilts.

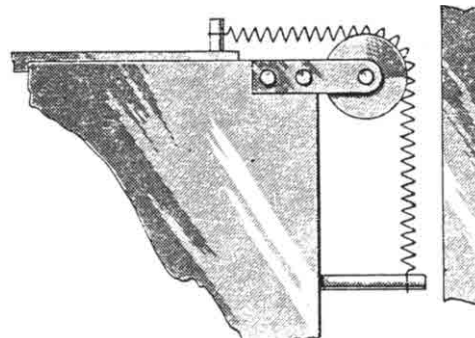

The spring wheel helps to distribute deflection over more coils that if the spring rested on the corner. The result is less fatigue and longer life.

OVERRIDING SPRING MECHANISMS FOR LOW-TORQUE DRIVES

Overriding spring mechanisms are widely used in the design of instruments and controls. All of the arrangements illustrated allow an incoming motion to override the outgoing motion whose limit has been reached. In an instrument, for example, the spring mechanism can be placed between the sensing and

indicating elements to provide overrange protection. The dial pointer is driven positively up to its limit before it stops while the input shaft is free to continue its travel. Six of the mechanisms described here are for rotary motion of varying amounts. The last is for small linear movements.

Fig. 1 Unidirectional override. The take-off lever of this mechanism can rotate nearly 360°. Its movement is limited only by one stop pin. In one direction, motion of the driving shaft is also impeded by the stop pin. But in the reverse direction the driving shaft is capable of rotating approximately 270° past the stop pin. In operation, as the driving shaft is turned clockwise, motion is transmitted through the bracket to the take-off lever. The spring holds the bracket against the drive pin. When the take-off lever has traveled the desired limit, it strikes the adjustable stop pin. However, the drive pin can continue its rotation by moving the bracket away from the drive pin and winding up the spring. An overriding mechanism is essential in instruments employing powerful driving elements, such as bimetallic elements, to prevent damage in the overrange regions.

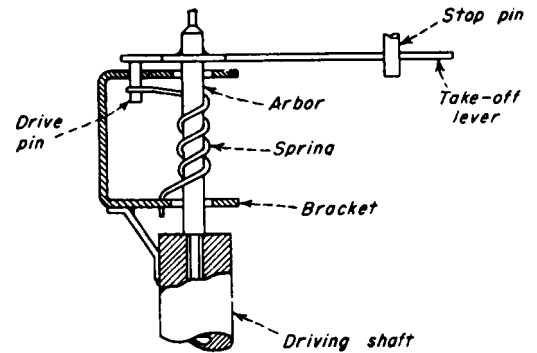

Fig. 2 Two-directional override. This mechanism is similar to that described under Fig. 1, except that two stop pins limit the travel of the take-off lever. Also, the incoming motion can override the outgoing motion in either direction. With this device, only a small part of the total rotation of the driving shaft need be transmitted to the take-off lever, and this small part can be anywhere in the range. The motion of the deriving shaft is transmitted through the lower bracket to the lower drive pin, which is held against the bracket by the spring. In turn, the lower drive pin transfers the motion through the upper bracket to the upper drive pin. A second spring holds this pin against the upper drive bracket. Because the upper drive pin is attached to the take-off lever, any rotation of the drive shaft is transmitted to the lever, provided it is not against either stop A or B. When the driving shaft turns in a counterclockwise direction, the take-off lever finally strikes against the adjustable stop A. The upper bracket then moves away from the upper drive pin, and the upper spring starts to wind up. When the driving shaft is rotated in a clockwise direction, the take-off lever hits adjustable stop B, and the lower bracket moves away from the lower drive pin, winding up the other spring. Although the principal applications for overriding spring arrangements are in instrumentation, it is feasible to apply these devices in the drives of heavy-duty machines by strengthening the springs and other load-bearing members.

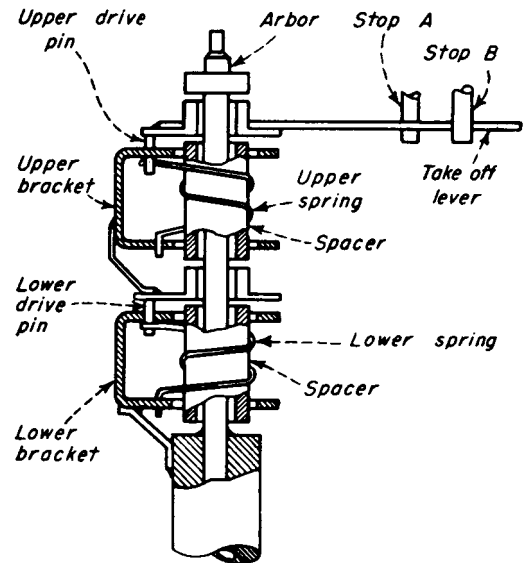
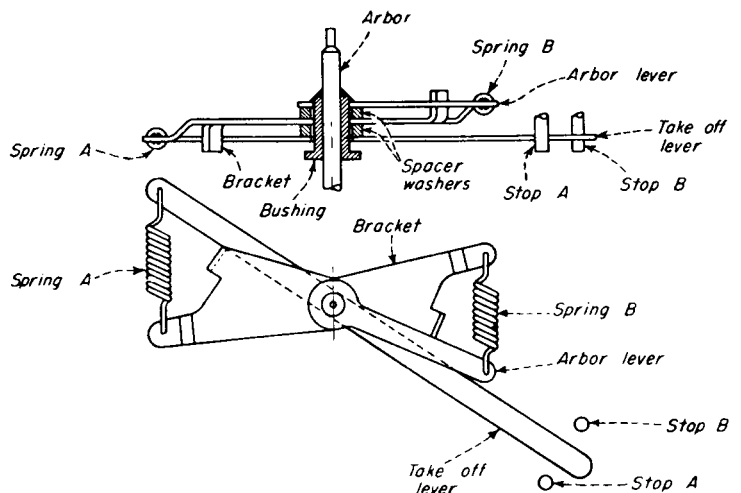

Fig. 3 Two-directional, limited-travel override. This mechanism performs the same function as that shown in Fig. 2, except that the maximum override in either direction is limited to about 40°. By contrast, the unit shown in Fig. 2 is capable of 270° movement. This device is suited for applications where most of the incoming motion is to be used, and only a small amount of travel past the stops in either direction is required. As the arbor is rotated, the motion is transmitted through the arbor lever to the bracket. The arbor lever and the bracket are held in contact by spring B. The motion of the bracket is then transmitted to the take-off lever in a similar manner, with spring A holding the take-off lever until the lever engages either stops A or B. When the arbor is rotated in a counterclockwise direction, the take-off lever eventually comes up against the stop B. If the arbor lever continues to drive the bracket, spring A will be put in tension.



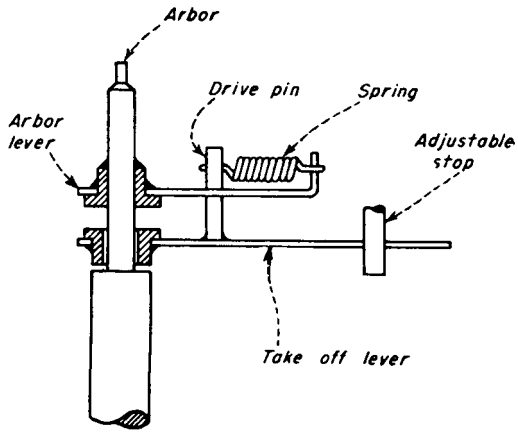

Fig. 4 Unidirectional, 90° override. This is a single overriding unit that allows a maximum travel of 90° past its stop. The unit, as shown, is arranged for overtravel in a clockwise direction, but it can also be made for a counterclockwise override. The arbor lever, which is secured to the arbor, transmits the rotation of the arbor to the take-off lever. The spring holds the drive pin against the arbor lever until the take-off lever hits the adjustable stop. Then, if the arbor lever continues to rotate, the spring will be placed in tension. In the counterclockwise direction, the drive pin is in direct contact with the arbor lever so that no overriding is possible.

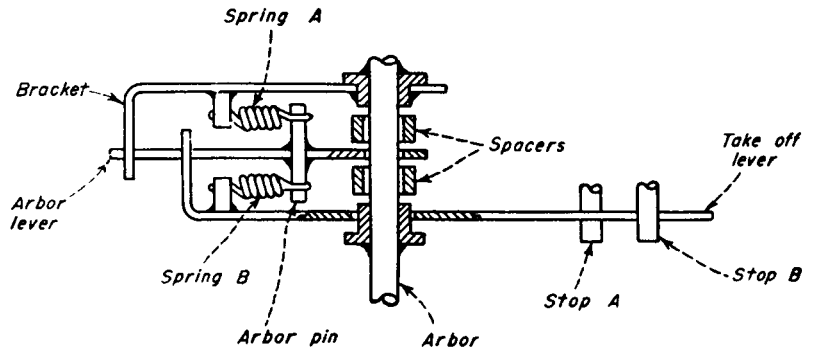

Fig. 5 Two-directional, 90° override. This double-overriding mechanism allows a maximum overtravel of 90° in either direction. As the arbor turns, the motion is carried from the bracket to the arbor lever, then to the take-off lever. Both the bracket and the take-off lever are held against the arbor lever by spring A and B. When the arbor is rotated counterclockwise, the takeoff lever hits stop A. The arbor lever is held stationary in contact with the take-off lever. The bracket, which is fastened to the arbor, rotates away from the arbor lever, putting spring A in tension. When the arbor is rotated in a clockwise direction, the take-off lever comes against stop B, and the bracket picks up the arbor lever, putting spring B in tension.

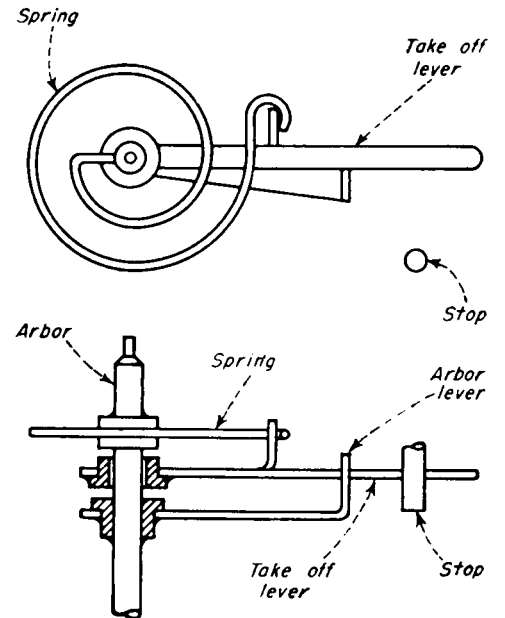

Fig. 6 Unidirectional, 90° override. This mechanism operates exactly the same as that shown in Fig. 4. However, it is equipped with a flat spiral spring in place of the helical coil spring used in the previous version. The advantage of the flat spiral spring is that it allows for a greater override and minimizes the space required. The spring holds the take-off lever in contact with the arbor lever. When the take-off lever comes in contact with the stop, the arbor lever can continue to rotate and the arbor winds up the spring.

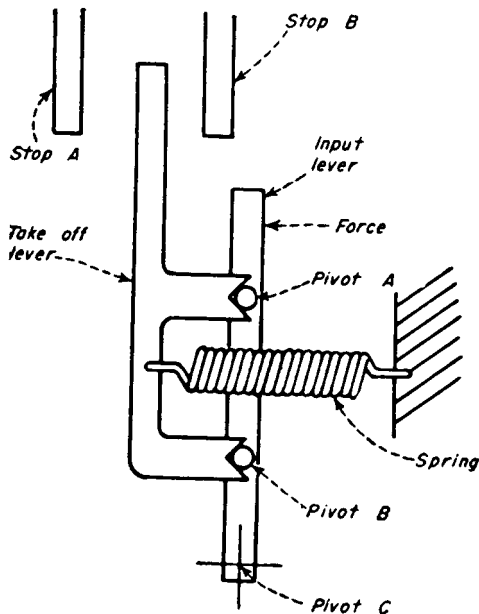
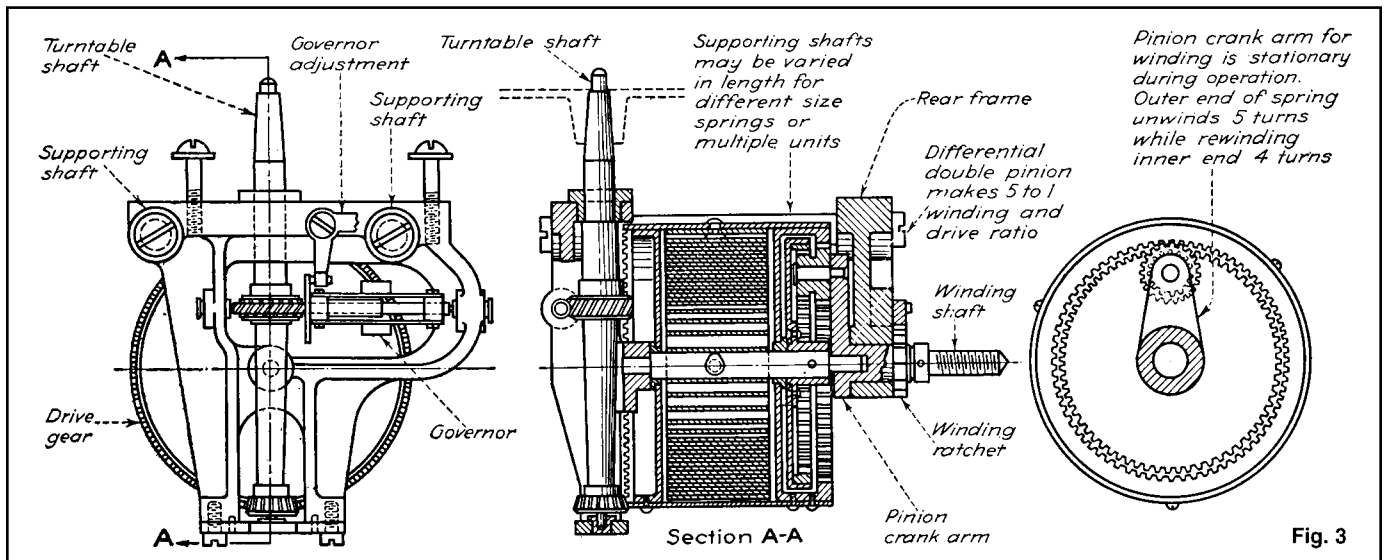
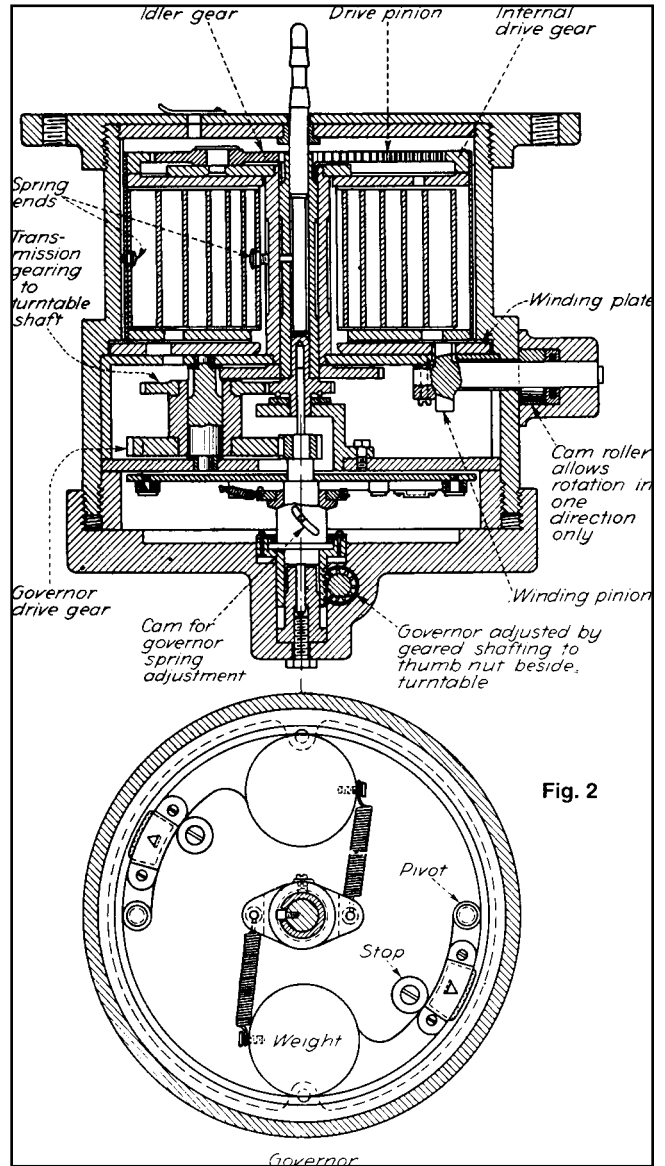
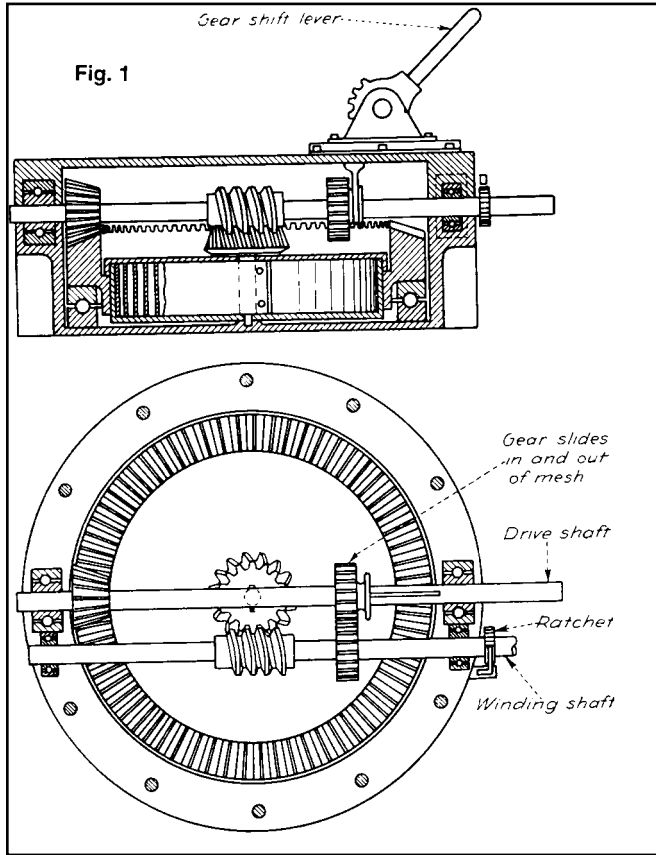

Fig. 7 Two-directional override, linear motion. The previous mechanisms were overrides for rotary motion. The device in Fig. 7 is primarily a double override for small linear travel, although it could be used on rotary motion. When a force is applied to the input lever, which pivots about point C, the motion is transmitted directly to the take-off lever through the two pivot posts, A and B. The take-off lever is held against these posts by the spring. When the travel causes the take-off lever to hit the adjustable stop A, the take-off lever revolves about pivot post A, pulling away from pivot post B, and putting additional tension in the spring. When the force is diminished, the input lever moves in the opposite direction until the take-off lever contacts the stop B. This causes the take-off lever to rotate about pivot post B, and pivot post A is moved away from the take-off lever.

SPRING MOTORS AND TYPICAL ASSOCIATED MECHANISMS

Many applications of spring motors in clocks, motion picture cameras, game machines, and other mechanisms offer practical ideas for adaptation to any mechanism that is intended to operate for an appreciable length of time. While spring motors are usually limited to comparatively small power application where other sources of power are unavailable or impracticable, they might also be useful for intermittent operation requiring comparatively high torque or high speed, using a low-power electric motor or other means for building up energy.



The accompanying patented spring motor designs show various methods for the transmission and control of spring-motor power. Flat-coil springs, confined in drums, are most widely used because they are compact, produce torque directly, and permit long angular displacement. Gear trains and feedback mechanisms reduce excess power drain so that power can be applied for a longer time. Governors are commonly used to regulate speed.

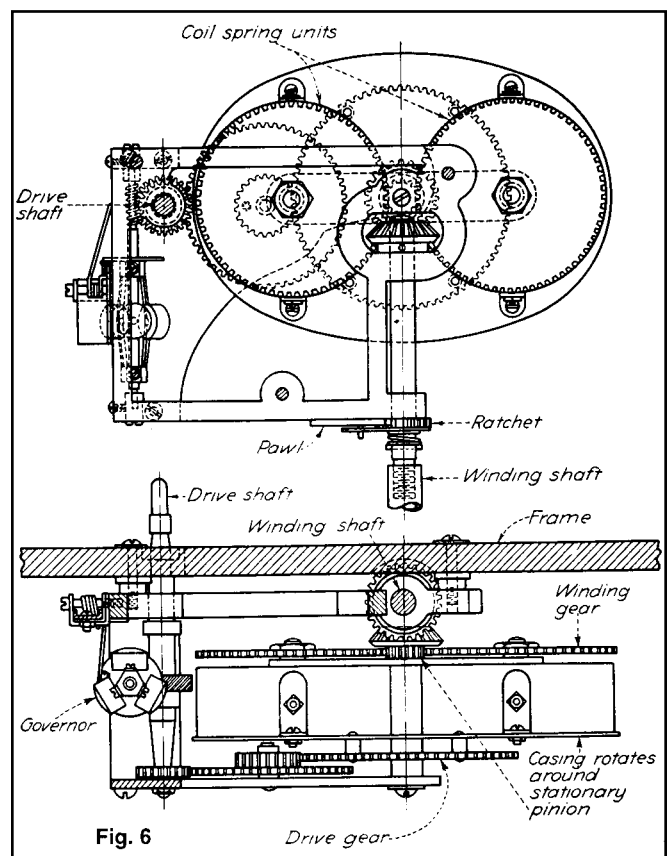
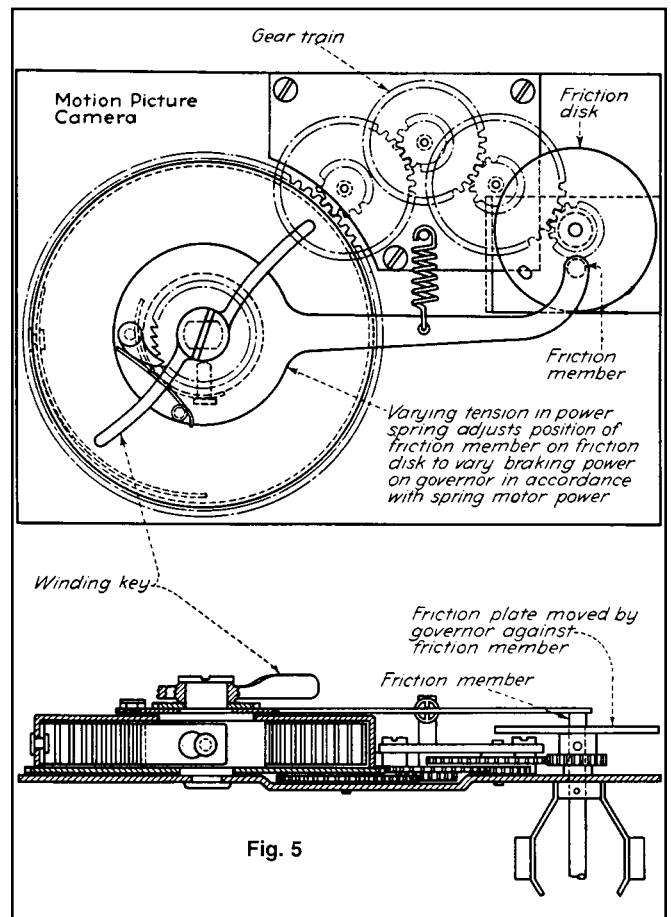
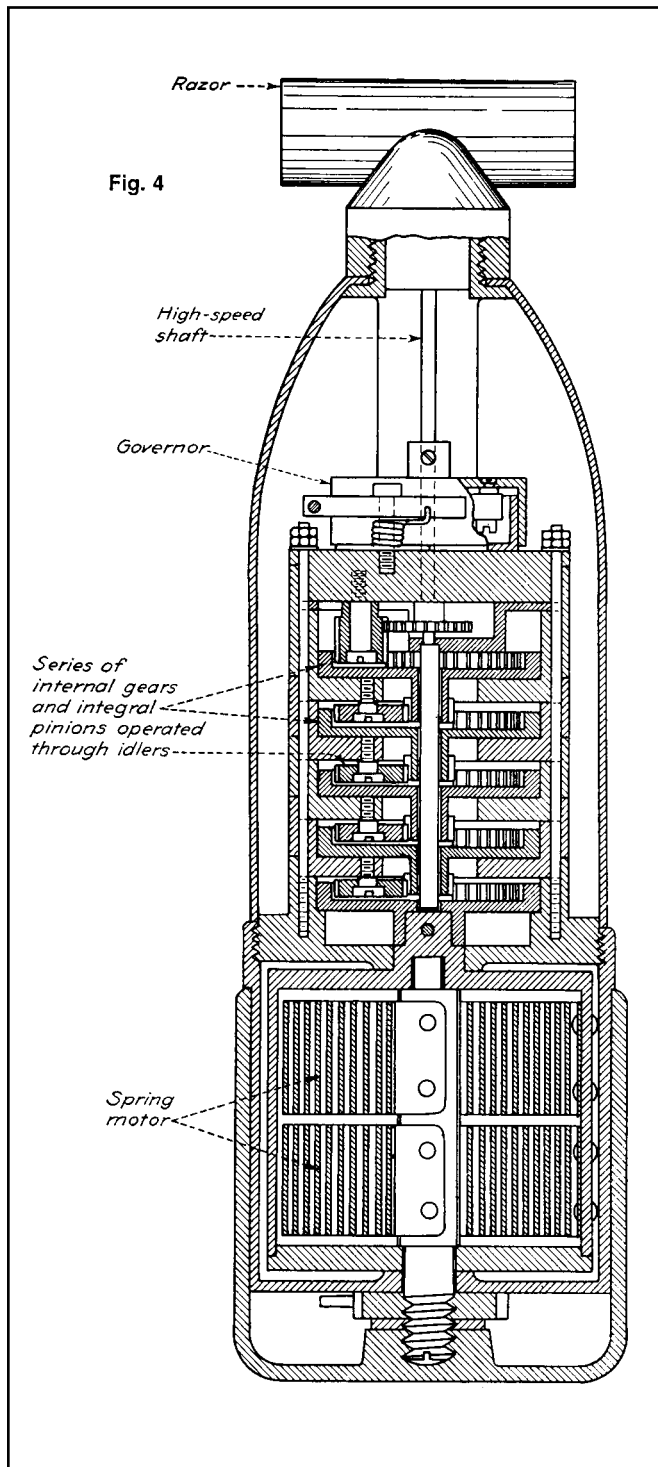

FLEXURES ACCURATELY SUPPORT PIVOTING MECHANISMS AND INSTRUMENTS

Flexures, often bypassed by various rolling bearing, have been making steady progress—often getting the nod for applications in space and industry where their many assets outweigh the fact that they cannot give the full rotation that bearings offer.

Flexures, or flexible suspensions as they are usually called, lie between the worlds of rolling bearings—such as the ball and roller bearings—and of sliding bearings—which include sleeve and hydrostatic bearings. Neither rolling nor sliding, flexures simply cross-suspend a part and flex to allow the necessary movement.

There are many applications for parts of components that must reciprocate or oscillate, so flexure are becoming more readily available as the off-the-shelf part with precise characteristics.

Flexures for space. Flexures have been selected over bearings in space

applications because they do not wear out, have simpler lubrication requirements, and are less subject to backlash.

One aerospace flexure—scarcely more than 2 in. high—was used for a key task on the Apollo Applications Program (AAP), in which Apollo spacecraft and hardware were employed for scientific research. The flexures' job was to keep a 5000-lb telescope pointed at the sun with unprecedented accuracy so that solar phenomena could be viewed.

The flexure pivot selected contained thin connecting beams that had flexing action so they performed like a combination spring and bearing.

Unlike a true bearing, however, it had no rubbing surfaces. Unloaded, or with a small load, a flexure pivot acts as a positive—or center-seeking—spring; loaded above a certain amount, it acts as a negative spring.

A consequence of this duality is that in space, the AAP telescope always returned to a central position, while dur-

ing ground testing it drifted away from center. The Lockheed design took advantage of this phenomenon of flexure pivots: By attaching a balancing weight to the telescope during ground tests, Lockheed closely simulated the dynamic conditions of space.

Potential of flexures. Lockheed adapted flexure pivots to other situations as well. In one case, a flexure was used for a gimbal mount in a submarine. Another operated a safety shutter to protect delicate sensors in a satellite.

Realizing the potential of flexure pivots, Bendix Corp. (Utica, N.Y.) developed an improved type of bearing flexure, commonly known as “flexure pivot.” It was designed to be compliant around one axis and rigid around the cross axes. The flexure pivots have the same kind of flat, crossed springs as the rectangular kind, but they were designed as a simple package that could be easily

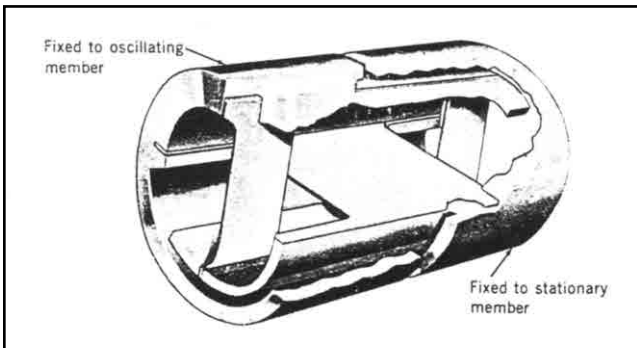

A frictionless flexure pivot, which resembles a bearing, is made of flat, angular crossed springs that support rotating sleeves in a variety of structural designs.

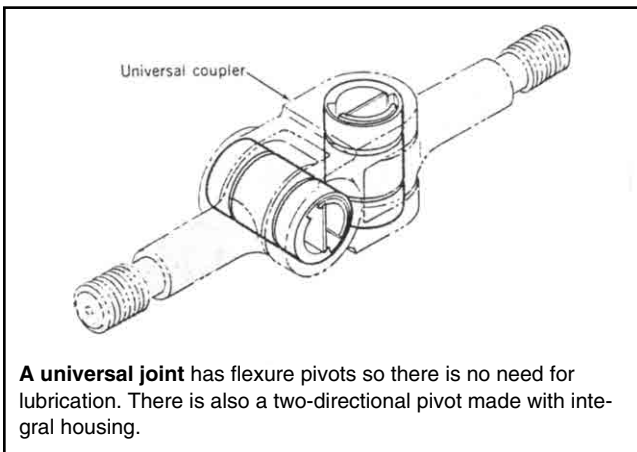

A universal joint has flexure pivots so there is no need for lubrication. There is also a two-directional pivot made with integral housing.

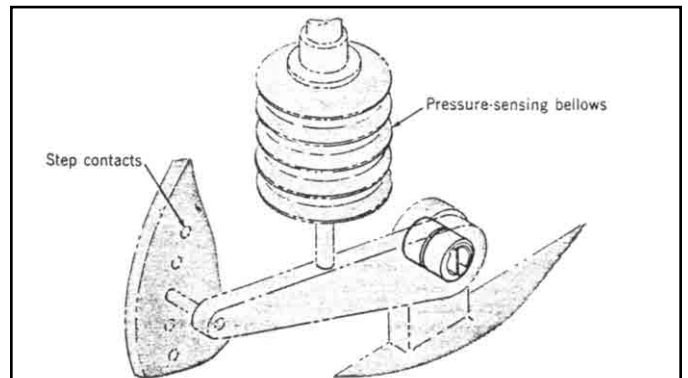

A pressure transducer with a flexure pivot can oscillate 30° to translate the movements of bellows expansion and contraction into electrical signals.

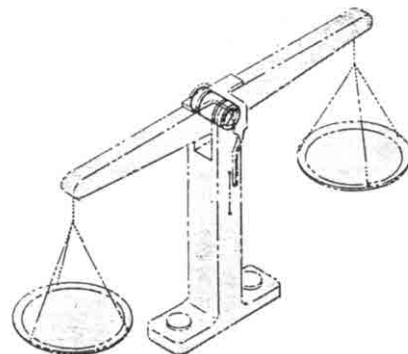

A balance scale substitutes flexure pivots in place of a knife edge, which can be affected by dirt, dust, and sometimes even by the lubricants themselves.

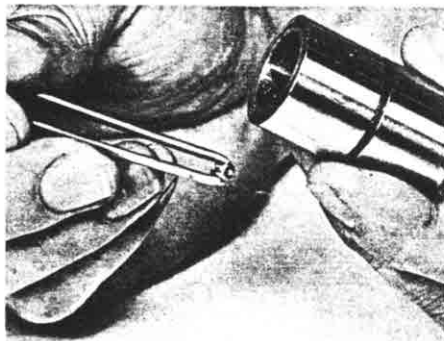
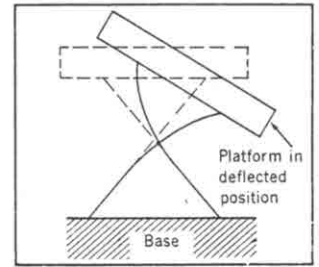
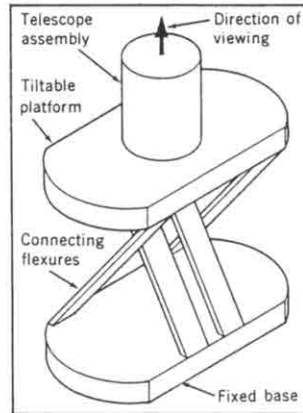
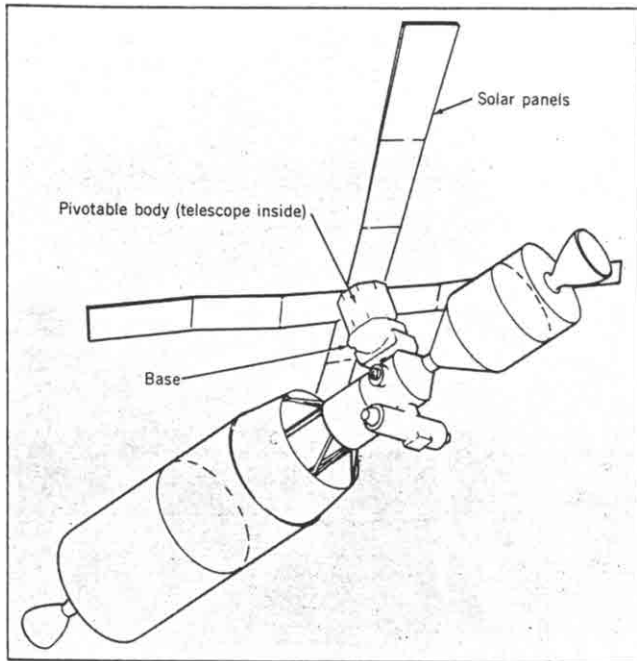

The Apollo telescope-mount cluster (top left) had flexures for tilting an X-ray telescope. The platform (top right) is tilted without break-away torque. The photo above shows typical range of flexure sizes.

installed and integrated into a design (see photo). The compactness of the flexure pivot make it suitable to replace ordinary bearings in many oscillating applications (see drawings).

The Bendix units were built around three elements: flexures, a core or inner housing, and an outer housing or mounting case. They permit angular deflections of $7\frac{1}{2}^\circ$, 15° , or 30° .

The cantilever type (see drawing) can support an overhung load. There is also a double-ended kind that supports central loads. The width of each cross member of the outer flexure is equal to one-half that of the inner flexure, so that when assembled at 90° from each other, the total flexure width in each plane is the same.

Key point. The heart of any flexure pivot is the flexure itself.

A key factor in applying a flexure is the torsional-spring constant of the assembly—in other words, the resisting restoring torque per angle of twist, which can be predicted from the following equation:

$$K = C \frac{NEbt^3}{12L}$$

where K = spring constant, in.-lb/deg
 N = number of flexures of width b
 E = modulus of elasticity, lb/in.²
 b = flexure width, in.
 t = flexure thickness, in.
 L = flexure length, in.
 C = summation of constants resulting from variations in tolerances and flexure shape.

Flat Springs Serve as a Frictionless Pivot

A flexible mount, suspended by a series of flat vertical springs that converge spoke-like from a hub, is capable of piv-

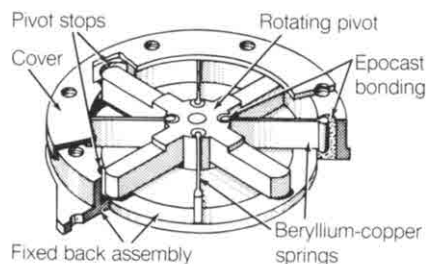

An assembly of flat springs gives accurate, smooth pivoting with no starting friction.

oting through small angles without any friction. The device, developed by C. O. Highman of Ball Bros. Research Corp. under contract to Marshall Space Flight Center, Huntsville, Ala., is also free of any hysteresis when rotated (it will return exactly to its position before being pivoted). Moreover, its rotation is smooth and linearly proportional to torque.

The pivot mount, which in a true sense acts as a pivot bearing without need for any lubrication, was developed with the aim of improving the pointing accuracies of telescopes, radar antennas, and laser ranging systems. It has other interesting potential applications, however. When the pivot mount is supported by springs that have different thermal expansion coefficients, for example, heat applied to one spring segment produces an angular rotation independent of external drive.

Flexing springs. The steel pivot mount is supported by beryllium-copper springs attached to the outer frame. Stops limit the thrust load. The flexure spring constant is about 4 ft-lb/radian.

The flexible pivot mount can be made in tiny sizes, and it can be driven by a dc torque motor or a mechanical linkage. In general, the mount can be used in any application requiring small rotary motion with zero chatter.

TAUT BANDS AND LEADSCREW PROVIDE ACCURATE ROTARY MOTION

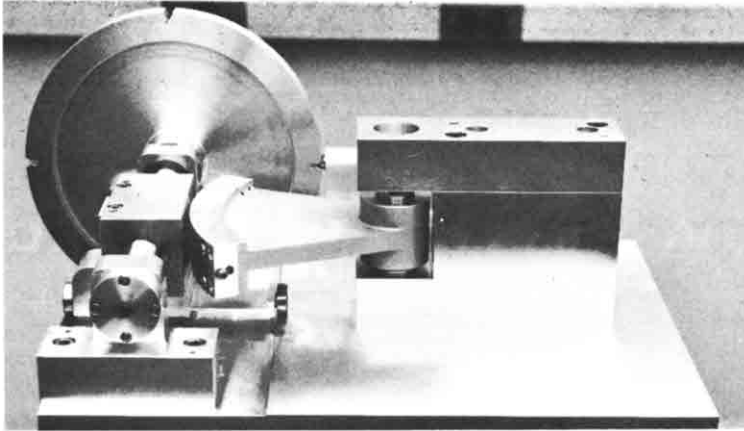

Flexible bands substitute for a worm gear in a precisely repeatable rotary mechanism used as a star tracker. The tracker instrumentation, mounted on the platform, is rotated by an input motion to the lead screw.

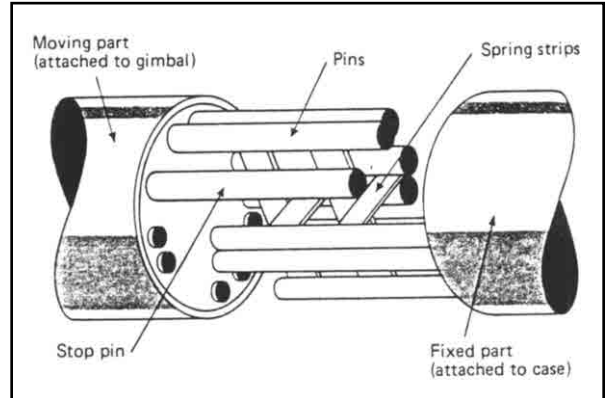

A flexure pivot boasts high mechanical stability for use in precision instruments.

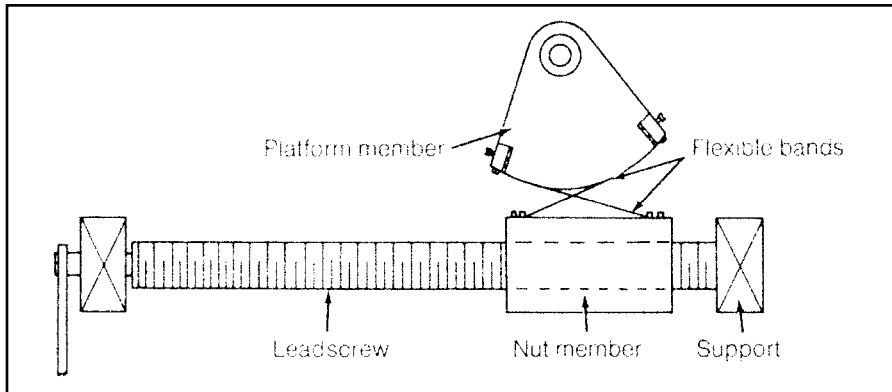

A pair of opposed, taut, flexible bands in combination with a lead screw provides an extremely accurate technique for converting rotary motion in one plane to rotary motion in another plane. Normally, a worm-gear set would be employed for such motion. The technique, however, developed by Kenneth G. Johnson of Jet Propulsion Laboratory, Pasadena, California, under a NASA sponsored project, provided repeatable, precise positioning within two seconds of an arc for a star tracker mechanism (drawing, photo).

Crossed bands. In the mechanism, a precision-finished lead screw and a fitted mating nut member produce linear translatory motion. This motion is then transformed to a rotary movement of a pivotal platform member. The transformation was achieved by coupling the nut member and the platform member through a pair of crossed flexible phosphor-bronze bands.

The precision lead screw is journaled at its ends in the two supports.

With the bands drawn taut, the lead screw is rotated to translate the nut member. The platform member will be drawn

about its pivot without any lost motion or play. Because the nut member is accurately fitted to the lead screw, and because precision-ground lead screws have a minimum of lead error, the uniform linear translation produced by rotation of the lead screw resulted in a uniform angular rotation of the platform member.

Points on the radial periphery of the sector are governed by the relationship $S = R\theta$, which means that rotation is directly proportional to distance as measured at the circumference. The nut that translates on the lead screw was directly related to the rotary input because the lead screw was accurately ground and lapped. Also, 360° of rotation of the lead screw translates the saddle nut a distance of one thread pitch. This translation result in rotation of the sector through an angle equal to S/R .

The relationship is true at any point within the operating range of the instrument, provided that R remains constant. Two other necessary conditions for maintaining relationship are that the saddle nut be constrained against rotation,

and that there be a zero gap between sector and saddle nut.

Pivots with a Twist

A multipin flexure-type pivot, developed by Smiths Industries in England, combined high radial and axial stiffness with the inherent advantages of a cross-spring pivot—which it is.

The pivot provides non-sliding, non-rolling radial and axial support without the need for lubrication. The design combines high radial and axial stiffness with a relatively low and controlled angular stiffness. Considerable attention was given to solving the practical problems of mounting the pivot in a precise and controlled way.

The finished pivot is substantially free from residual mechanical stress to achieve stability in service. Maraging steel is used throughout the assembly to avoid any differential expansion due to material mismatch. The blades of the flexure pivot are free from residual braze to avoid any bimetallic movements when the temperature of the pivot changes.

The comparatively open construction of the pivot made it less susceptible to jamming caused by any loose particles. Furthermore, the simple geometric arrangement of the support pins and flexure blade allowed blade anchor points to be defined with greater accuracy. The precision ground integral mounting flanges simplified installation.

Advantages, according to its designer, include frictionless, stictionless and negligible hysteresis characteristics. The bearing is radiation-resistant and can be used in high vacuum conditions or in environments where there is dirt and contamination.

AIR SPRING MECHANISMS

EIGHT WAYS TO ACTUATE MECHANISMS WITH AIR SPRINGS

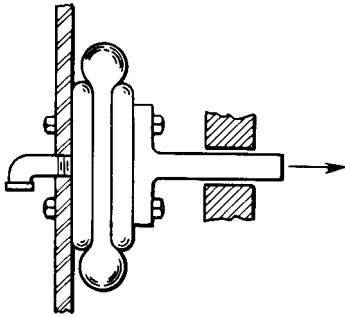

Linear force link: A one- or two-convolution air spring drives the guide rod. The rod is returned by gravity, opposing force, metal spring or, at times, internal stiffness of an air spring.

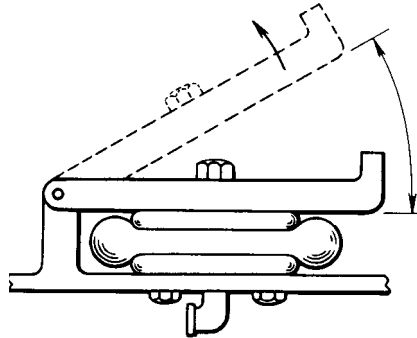

Rotary force link: A pivoted plate can be driven by a one-convolution or two-convolution spring to 30° of rotation. The limitation on the angle is based on permissible spring misalignment.

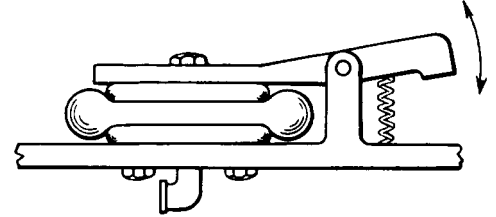

Clamp: A jaw is normally held open by a metal spring. Actuation of the air spring then closes the clamp. The amount of opening in the jaws of the clamp can be up to 30° of arc.

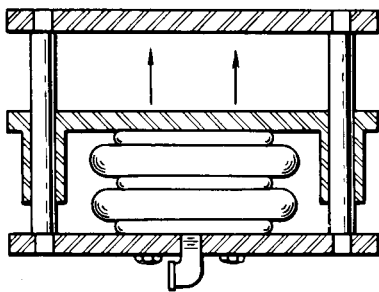

Direct-acting press: One-, two-, or three-convolution air springs are assembled singly or in gangs. They are naturally stable when used in groups. Gravity returns the platform to its starting position.

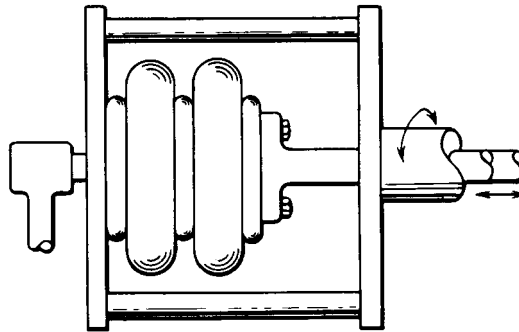

Rotary shaft actuator: The activator shifts the shaft longitudinally while the shaft is rotating. Air springs with one, two, or three convolutions can be used. A standard rotating-air fitting is required.

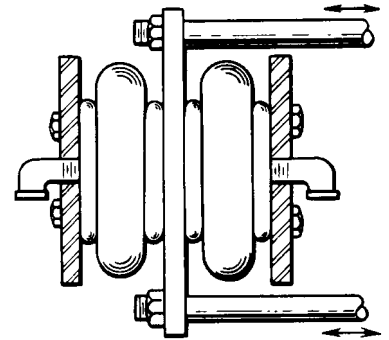

Reciprocating linear force link: It reciprocates with one-, two-, or three-convolution air springs in a back-to-back arrangement. Two- and three-convolution springs might need guides for their force rods.

POPULAR TYPES OF AIR SPRINGS

Air is an ideal load-carrying medium. It is highly elastic, its spring rate can be easily varied, and it is not subject to permanent set.

Air springs are elastic devices that employ compressed air as the spring element. They maintain a soft ride and a constant vehicle height under varying load. In industrial applications they control vibration (isolate or amplify it) and actuate linkages to provide either rotary or linear movement. Three kinds of air springs (bellows, rolling sleeve, and rolling diaphragm) are illustrated.

Bellows Type

A single-convolution spring looks like a tire lying on its side. It has a limited

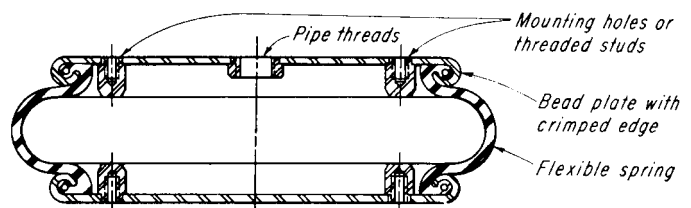

ONE-CONVOLUTION BELLOW

stroke and a relatively high spring rate. Its natural frequency is about 150 cpm without auxiliary volume for most sizes, and as high as 240 cpm for the smallest size. Lateral stiffness is high (about half

the vertical rate); therefore the spring is quite stable laterally when used for industrial vibration isolation. It can be filled manually or kept inflated to a constant height if is connected to factory air

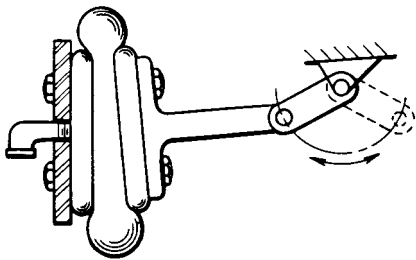

Pivot mechanism: It rotates a rod through 145° of rotation. It can accept a 30° misalignment because of the circular path of its connecting-link pin. A metal spring or opposing force retracts the link.

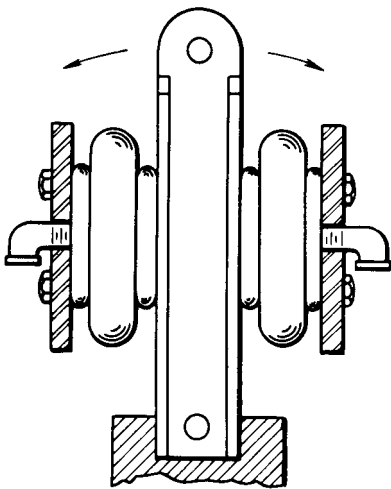

Reciprocating rotary motion with one-convolution and two-convolution springs. An arc up to 30° is possible. It can pair a large air spring with a smaller one or a lengthen lever.

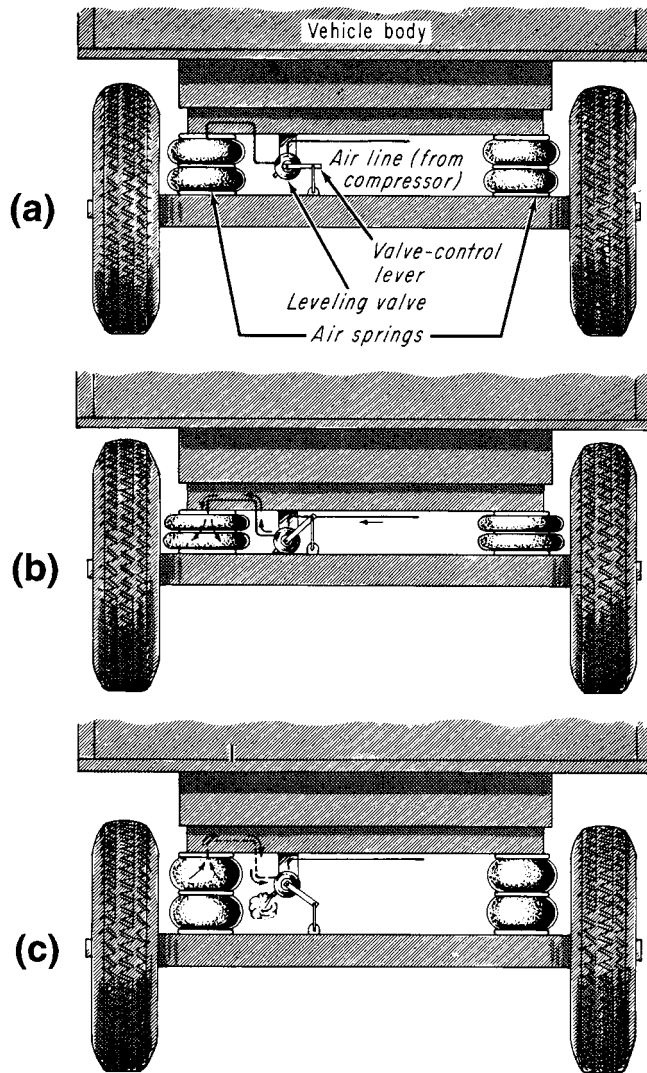

Air suspension on vehicle: A view of normal static conditions—air springs at desired height and height-control valve closed (a). When a load is added to the vehicle—the valve opens to admit air to the springs and restore height, but at higher pressure (b). With load removed from the vehicle—valve permits bleeding off excess air pressure to atmosphere and restores its design height (c).

supply through a pressure regulator. This spring will also actuate linkages where short axial length is desirable. It is seldom used in vehicle suspension systems.

Rolling-Sleeve Type

This spring is sometimes called the reversible-sleeve or rolling-lobe type. It has a telescoping action—the lobe at the bottom of the spring rolls up and down along the piston. The spring is used primarily in vehicle suspensions because lateral stiffness is almost zero.

Rolling-Diaphragm Type

These are laterally stable and can be used as vibration isolators, actuators, or constant-force spring. But because of

their negative effective-area curve, their pressure is not generally maintained by pressure regulators.

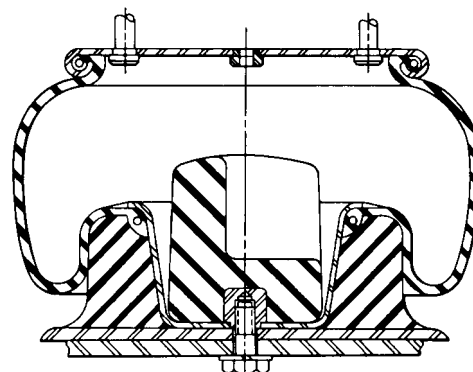

ROLLING-SLEEVE

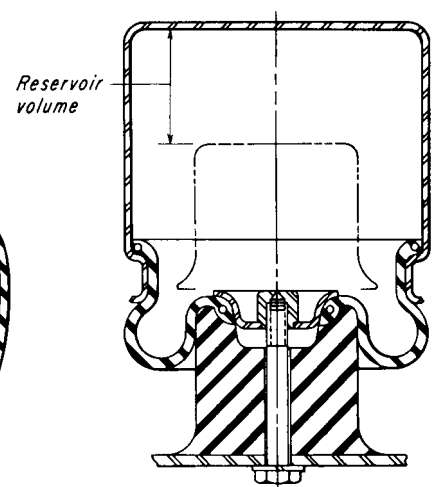

ROLLING-DIAPHRAGM

OBTAINING VARIABLE RATES FROM SPRINGS

How stops, cams, linkages, and other arrangements can vary the load/deflection ratio during extension or compression



With tapered-pitch spring the number of effective coils changes with deflection—the coils “bottom” progressively.

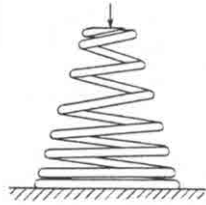

A tapered outside diameter and pitch combine to produce a similar effect except that the spring with tapered O.D. will have a shorter solid height.

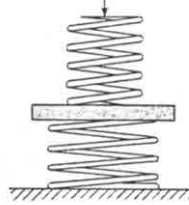

In dual springs, one spring closes completely before the other.

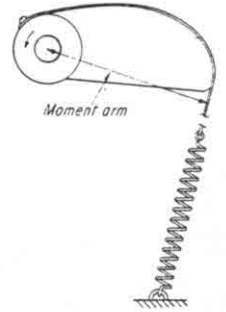

A cam-and-spring device causes the torque relationship to vary during rotation as the moment arm changes.

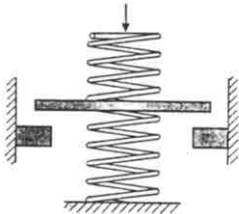
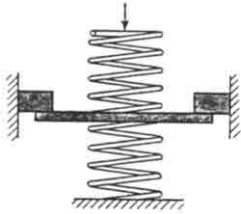

Stops can be used with either compression or extension springs.

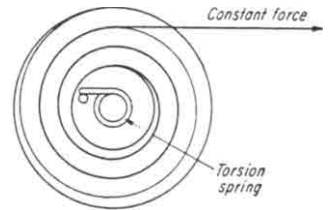

Torsion spring combined with a variable-radius pulley gives a constant force.

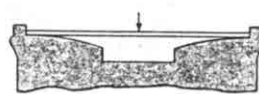
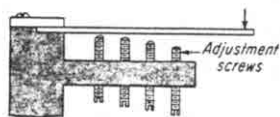
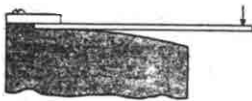

Leaf springs can be arranged so that their effective lengths change with deflection.

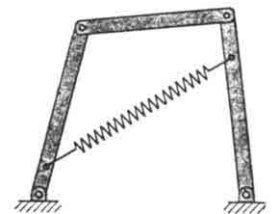

A four-bar mechanism in conjunction with a spring has a wide variety of load/deflection characteristics.

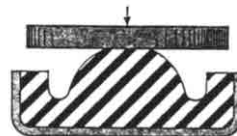
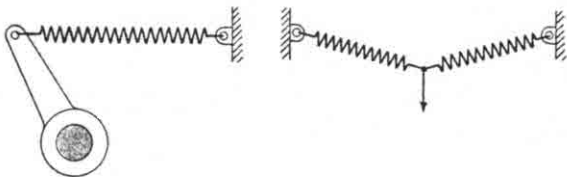

A molded-rubber spring has deflection characteristics that vary with its shape.

These linkage-type arrangements are used in instruments where torque control or anti-vibration suspension is required.

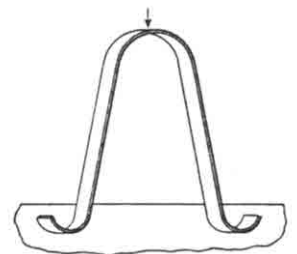

An arched leaf-spring gives an almost constant force when it is shaped like the one illustrated.

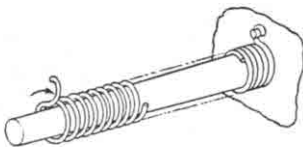

With a tapered mandrel and torsion spring the effective number of coils decreases with torsional deflection.

BELLEVILLE SPRINGS

Belleville springs are low-profile conical rings with differing height (h) to thickness (t) ratios, as shown in Fig. 1. Four way to stack them are shown in Fig. 2.

Belleville springs lend themselves to a wide variety; of applications:

For height to spring ratios of about 0.4—A linear spring rate and high load resistance with small deflections.

For height to spring ratios between 0.8 and 1.0—An almost linear spring rate for fasteners and bearing and in stacks.

For ratios of around 1.6—A constant (flat) spring rate starting at about 60% of the deflection (relative to the fully compressed flat position) and proceeding to the flat position and, if desired, on to the flipped side to a deflection of about 140%. In most applications, the flat position is the limit of travel, and for deflections beyond the flat, the contact elements must be allowed unrestricted travel

One application of bellevilles with constant spring rate is on live spindles on the tailpiece of a lathe. The work can be loaded on the lathe, and as the piece heats up and begins to expand, the belleville will absorb this change in length without adding any appreciable load.

For high height to spring ratios exceeding about 2.5—The spring is stiff, and as the stability point (high point on the curve) is passed the spring rate becomes negative causing resistance to drop rapidly. If allowed, the belleville will snap through the flat position. In other words, it will turn itself inside out.

Working in groups. Belleville washers stacked in the parallel arrangement have been used successfully in a variety of applications.

One is a pistol or rifle buffer mechanism (Fig. 3) designed to absorb repeated, high-energy shock loads. A preload nut predeflects the washers to stiffen their resistance. The stacked washers are guided by a central shaft, an outside guide cylinder, guide rings, or a combination of these.

A wind-up starter mechanism for diesel engines (shown in Fig. 4) replaces a heavy-duty electric starter or auxiliary gas engine. To turn over the engine, energy is manually stored in a stack of bellevilles compressed by a hand crank. When released, the expanding spring pack rotates a pinion meshed with the flywheel ring gear to start the engine.

Figure 5 shows a belleville as a loading spring for a clutch.

Popular arrangements

Fig. 1 Basic belleville

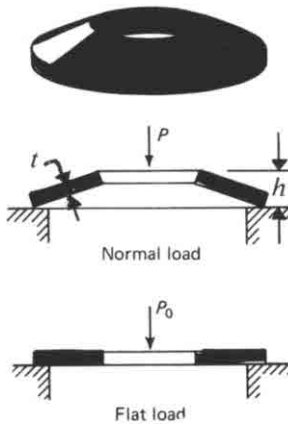

Fig. 2 Four ways to stack

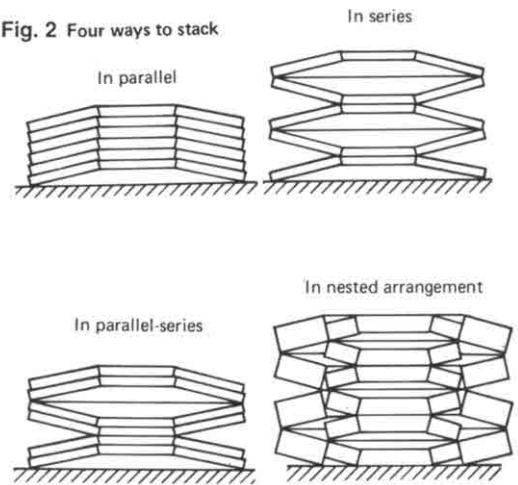
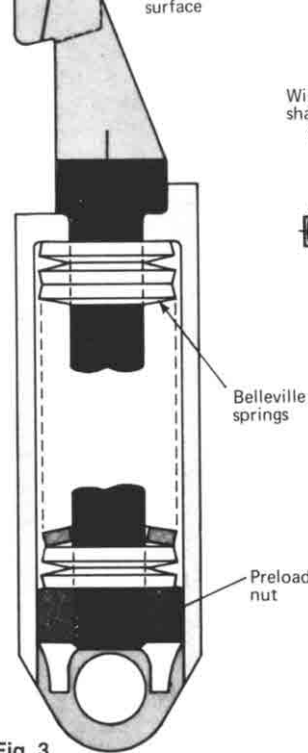

Fig. 3



Buffer mechanism for high-impact energy

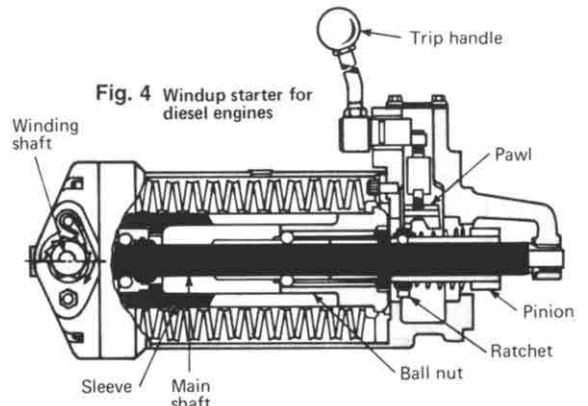

Fig. 4 Windup starter for diesel engines

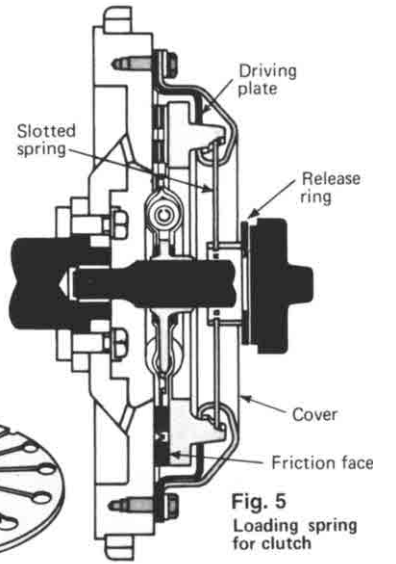
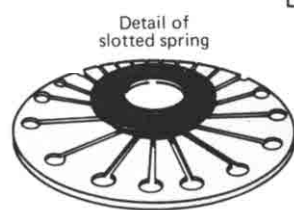

Fig. 5 Loading spring for clutch

SPRING-TYPE LINKAGE FOR VIBRATION CONTROL

Do you need a buffer between vibrating machinery and the surrounding structure? These isolators, like capable fighters, absorb the light jabs and stand firm against the forces that inflict powerful haymakers

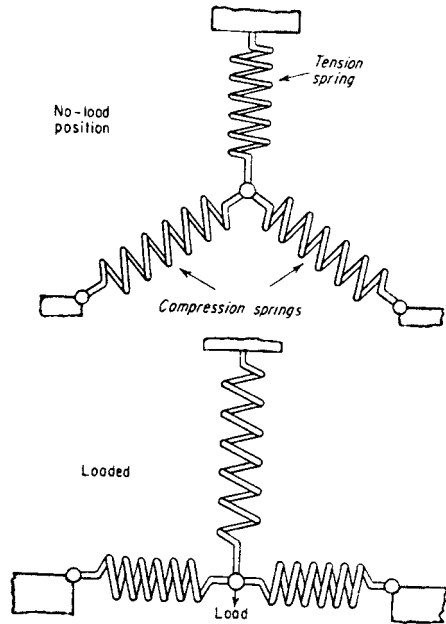

Fig. 1 This basic spring arrangement has zero stiffness, and is as "soft as a cloud" when compression springs are in line, as illustrated in the loaded position. But change the weight or compression-spring alignment, and stiffness increases greatly. This support is adequate for vibration isolation because zero stiffness give a greater range or movement than the vibration amplitude generally in the hundredths-of-an-inch range. Arrangements shown here are highly absorbent when required, yet provide a firm support when large force changes occur. By contrast, isolators that depend upon very "soft" springs, such as the sine spring, are unsatisfactory in many applications; they allow a large movement of the supported load with any slight weight change or large-amplitude displacing force.

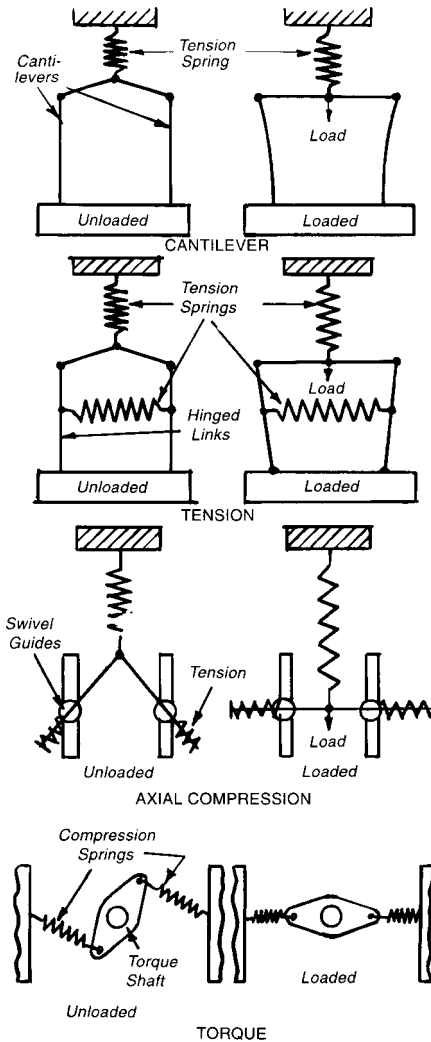

Fig. 2 Alternative arrangements illustrate adaptability of basic design. Here, instead of the inclined, helical compression springs, wither tension or cantilever springs can serve. Similarly, different type of springs can replace the axial, tension spring. Zero torsional stiffness can also be provided.

Various applications of the principle of vibration isolation show how versatile the design is. Coil spring (Fig. 4) as well as cantilever and torsion-bar suspension of automobiles can all be reduced in stiffness by adding an inclined spring; stiffness of the tractor seat (Fig. 5) and, consequently, transmitted shocks can be similarly reduced. Mechanical tension meter (Fig. 6) provides a sensitive indication of small variations in tension. A weighing scale, for example, could detect small variations in nominally identical objects. A nonlinear torque mete (Fig. 7) provides a sensitive indication of torque variations about a pre-determined level.

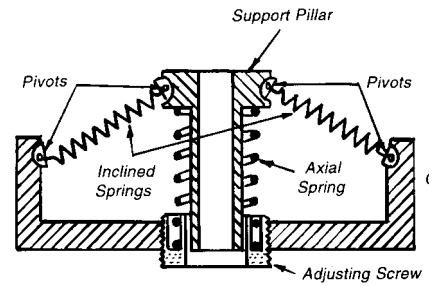

Fig. 3 A general-purpose support is based on basic spring arrangement, except that an axial compression spring is substituted for a tension spring. Inclined compression springs, spaced around a central pillar, carry the component to be isolated. When a load is applied, adjustment might be necessary to bring the inclined springs to zero inclination. Load range that can be supported with zero stiffness on a specific support is determined by the adjustment range and physical limitations of the axial spring.

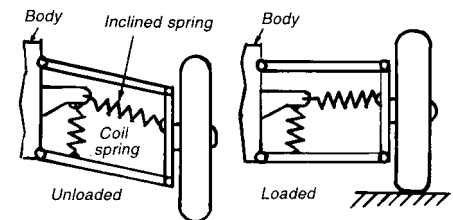

Fig. 4

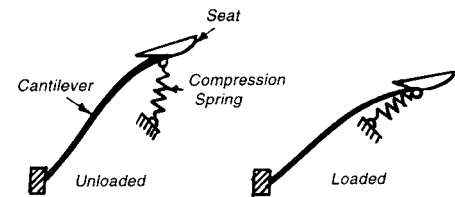

Fig. 5

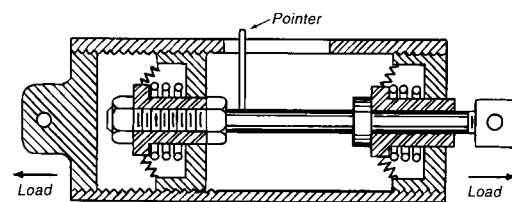

Fig. 6

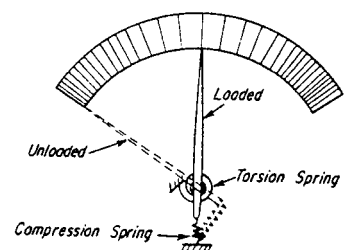

Fig. 7

TWENTY SCREW DEVICES

A threaded shaft and a nut plus some way to make one of these members rotate without translating and the other to translate without rotating are about all you need to do practically all of the adjusting, setting, or locking in a machine design.

Most of these applications have low-precision requirements. That's why the thread might be a coiled wire or a twisted strip; the nut might be a notched ear on a shaft or a slotted disk. Standard screws and nuts from hardware store shelves can often serve at very low cost.

Here are the basic motion transformations possible with screw threads (Fig. 1):

- Transform rotation into linear motion or reverse (A),
- Transform helical motion into linear motion or reverse (B),
- Transform rotation into helical motion or reverse (C).

Of course the screw thread can be combined with other components: in a four-bar linkage (Fig. 2), or with multiple screw elements for force or motion amplification.

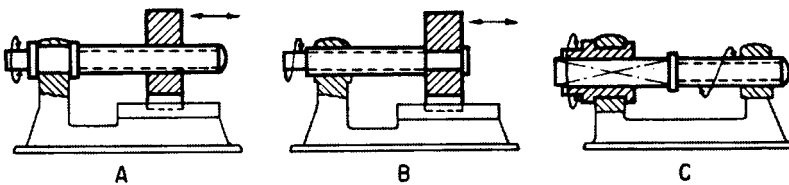

Fig. 1 Motion transformations of a screw thread include: rotation to translation (A), helical to translation (B), rotation to helical

(C). These are reversible if the thread is not self-locking. (The thread is reversible when its efficiency is over 50%.)

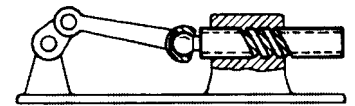

Fig. 2 Standard four-bar linkage has a screw thread substituted for a slider. The output is helical rather than linear.

Rotation to Translation

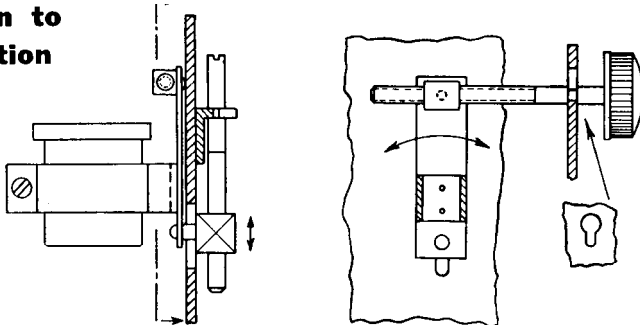

Fig. 3 A two-directional lamp adjustment with screwdriver will move a lamp up and down. A knob adjust (right) rotates the lamp about a pivot.

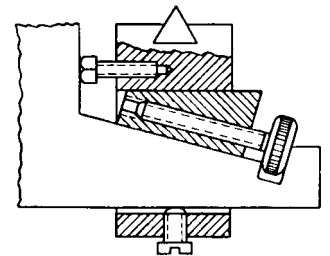

Fig. 4 A knife-edge bearing is raised or lowered by a screw-driven wedge. Two additional screws position the knife edge laterally and lock it.

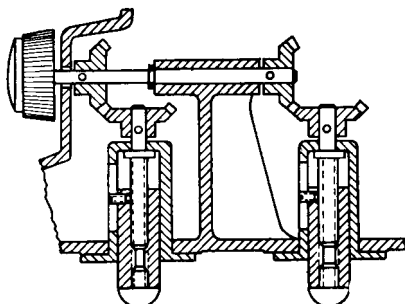

Fig. 5 A parallel arrangement of tandem screw threads raises the projector evenly.

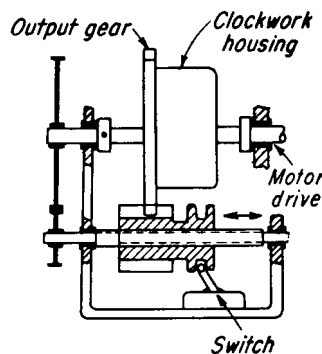

Fig. 6 Automatic clockwork is kept taut by an electric motor turned on and off by a screw thread and nut. The motor drive must be self-locking or it will permit the clock to unwind as soon as the switch is turned off.

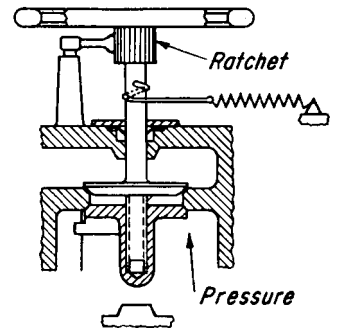

Fig. 7 A valve stem has two oppositely moving valve cones. When opening, the upper cone moves up first, until it contacts its stop. Further turning of the valve wheel forces the lower cone out of its seat. The spring is wound up at the same time. When the ratchet is released, the spring pulls both cones into their seats.

TRANSLATION TO ROTATION

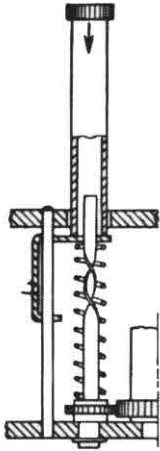

Fig. 8 A metal strip or square rod can be twisted to make a long-lead thread. It is ideal for transforming linear into rotary motion. Here a pushbutton mechanism winds a camera. The number of turns or dwell of the output gear is easily altered by changing (or even reversing) the twist of the strip.

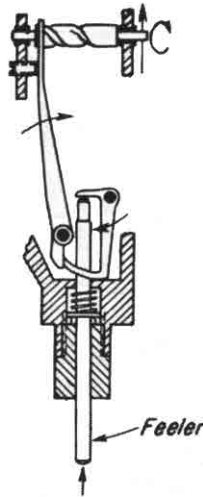

Fig. 9 A feeler gage has its motion amplified through a double linkage and then transformed to rotation for moving a dial needle.

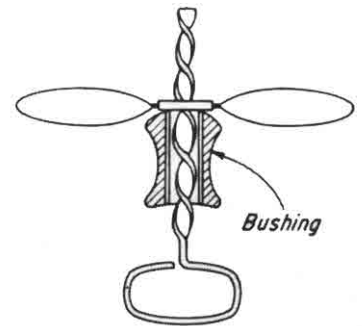

Fig. 10 The familiar flying propeller-toy is operated by pushing the bushing straight up and off the thread.

SELF-LOCKING

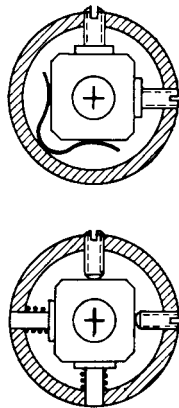

Fig. 11 A hairline adjustment for a telescope with two alternative methods for drive and spring return.

Fig. 12 This screw and nut form a self-locking drive for a complex linkage.

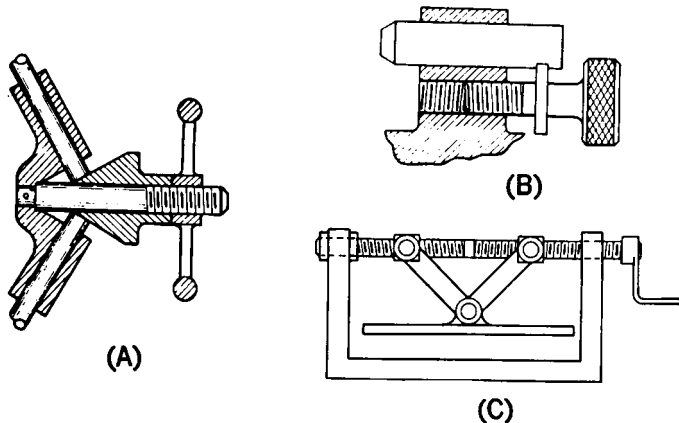
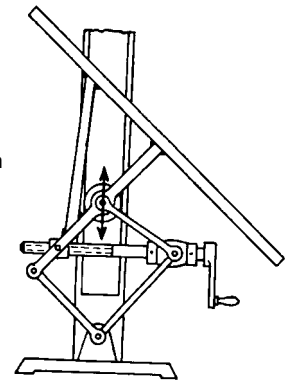

Fig. 13 Force translation. The threaded handle in (A) drives a coned bushing that thrusts rods outwardly for balanced pressure. The screw in (B) retains and drives a dowel pin for locking purposes. A right- and left-handed shaft (C) actuates a press.

DOUBLE THREADING

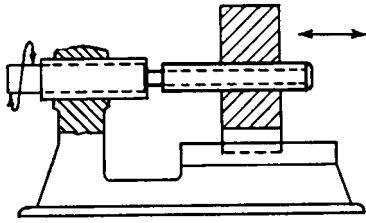

Fig. 14 Double-threaded screws, when used as differentials, permit very fine adjustment for precision equipment at relatively low cost.

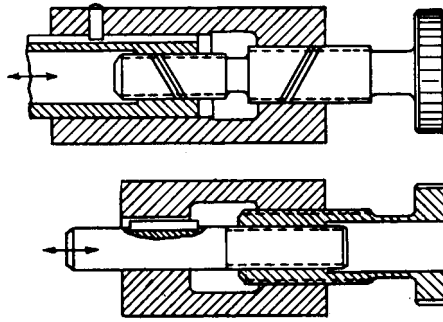

Fig. 15 Differential screws can be made in dozens of forms. Here are two methods: in the upper figure, two opposite-hand threads on a single shaft; in the lower figure, same-hand threads on independent shafts.

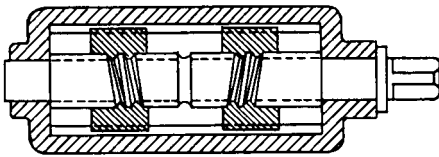

Fig. 16 Opposite-hand threads make a high-speed centering clamp out of two moving nuts.

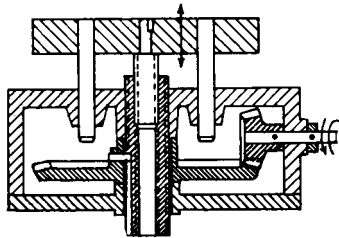

Fig. 17 A measuring table rises very slowly for many turns of the input bevel gear. If the two threads are $1\frac{1}{2}$ to 12 and $\frac{3}{4}$ to 16, in the fine-thread series, the table will rise approximately 0.004 in. per input-gear revolution.

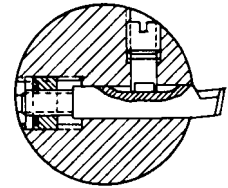

Fig. 18 A lathe turning tool in a drill rod is adjusted by a differential screw. A special double-pin wrench turns the intermediate nut, advancing the nut and retracting the threaded tool simultaneously. The tool is then clamped by a setscrew.

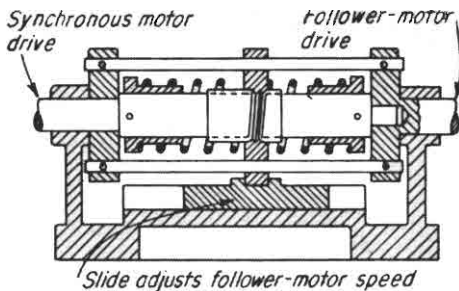

Fig. 19 Any variable-speed motor can be made to follow a small synchronous motor by connecting them to the two shafts of this differential screw. Differences in the number of revolutions between the two motors appear as motion of the traveling nut and slide, thus providing electrical speed compensation.

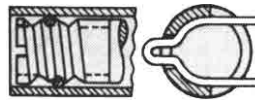

Fig. 20 A wire fork is the nut in this simple tube-and-screw device.

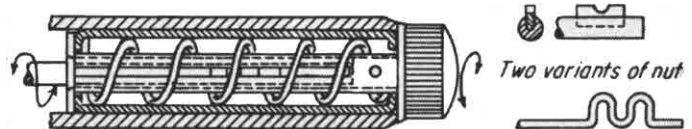
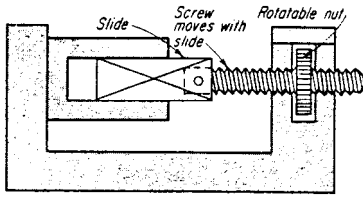

Fig. 21 A mechanical pencil includes a spring as the screw thread and a notched ear or a bent wire as the nut.

TEN WAYS TO EMPLOY SCREW MECHANISMS

Three basic components of screw mechanisms are: actuating member (knob, wheel, handle), threaded device (screw-nut set), and sliding device (plunger-guide set).



A nut can rotate but will not move longitudinally. Typical applications: screw jacks, heavy vertically moved doors; floodgates, opera-glass focusing, vernier gages, and Stillson wrenches.

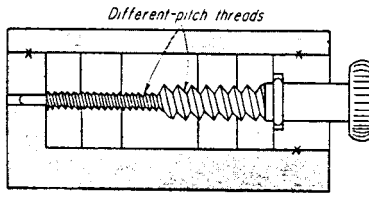

A differential movement is given by threads of different pitch. When the screw is rotated, the nuts move in the same direction but at different speeds.

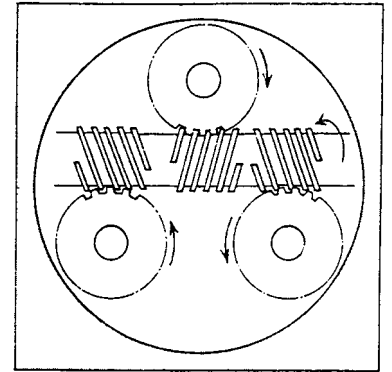

One screw actuates three gears simultaneously. The axes of gears are at right angles to that of the screw. This mechanism can replace more expensive gear setups where speed reduction and multiple output from a single input is required.

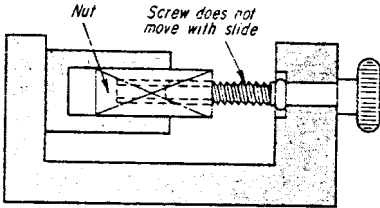

A screw can rotate but only the nut moves longitudinally. Typical applications: lathe tailstock feed, vises, lathe apron.

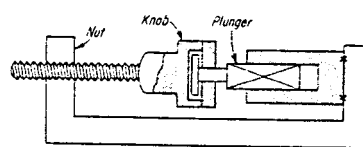

A screw and plunger are attached to a knob. The nut and guide are stationary. It is used on: screw presses, lathe steady-rest jaws for adjustment, and shaper slide regulation.

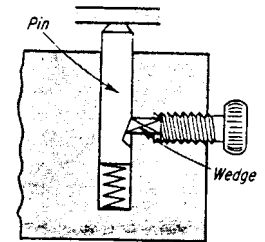

(A)

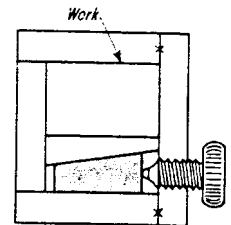

(B)

Screw-actuated wedges lock locating pin A and hold the work in fixture (B). These are just two of the many tool and diemaking applications for these screw actions.

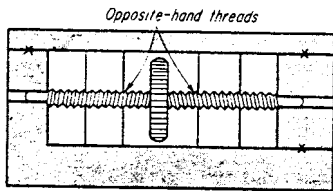

Opposing movement of lateral slides; adjusting members or other screw-actuated parts can be achieved with opposite-hand threads.

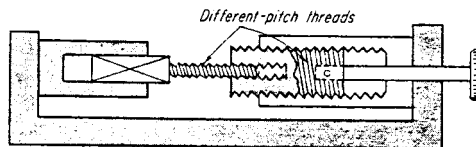

Concentric threading also gives differential movement. Such movements are useful wherever rotary mechanical action is required. A typical example is a gas-bottle valve, where slow opening is combined with easy control.

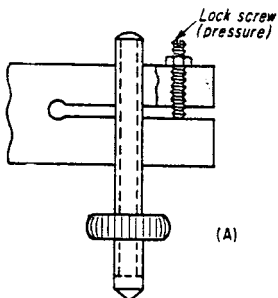

(A)

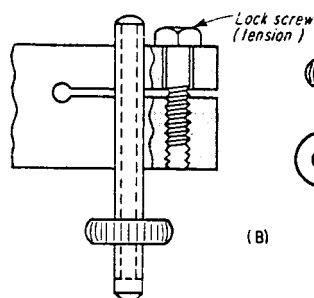

(B)

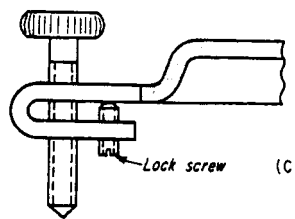

(C)

Adjustment screws are effectively locked by either a pressure screw (A) or tension screw (B). If the adjusting screw is threaded into a formed sheet-metal component (C), a setscrew can be used to lock the adjustment.

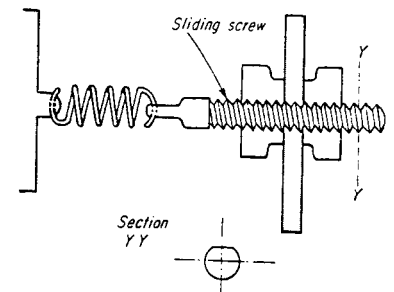

Locking nuts can be placed on opposite sides of a panel to prevent axial screw movement and simultaneously lock against vibrations. Drill-press depth stops and adjustable stops for shearing and cutoff dies are some examples.

SEVEN SPECIAL SCREW ARRANGEMENTS

Differential, duplex, and other types of screws can provide slow and fast feeds, minute adjustments, and strong clamping action.

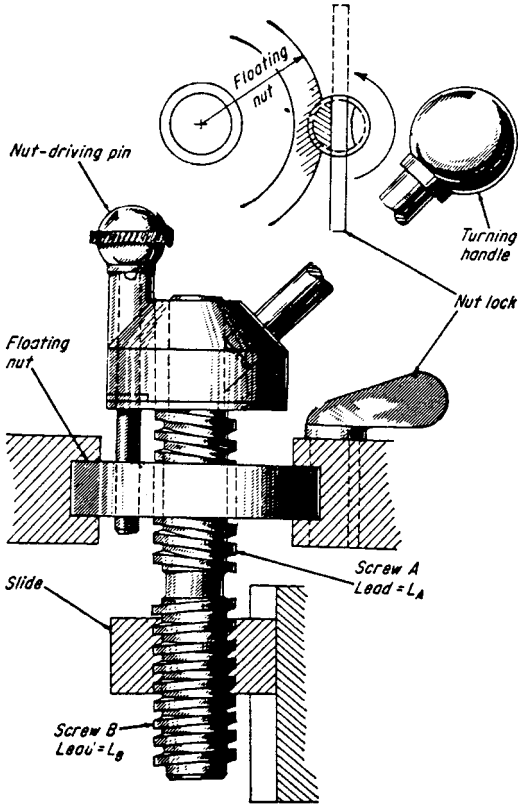

Rapid and slow feed. With left- and right-hand threads, slide motion with the nut locked equals L_A plus L_B per turn; with the nut floating, slide motion per turn equals L_B . Extremely fine feed with a rapid return motion is obtained when the threads are differential.

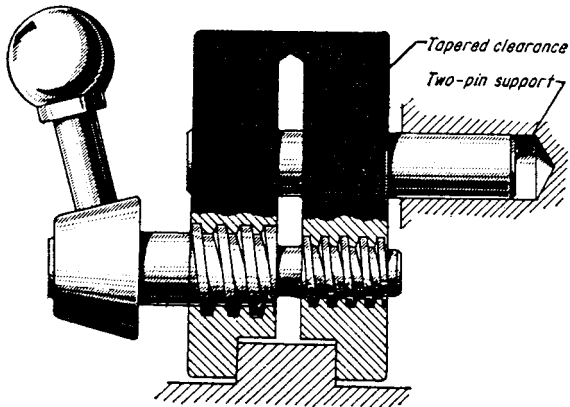

Differential clamp. This method of using a differential screw to tighten clamp jaws combines rugged threads with high clamping power. Clamping pressure, $P = Te [R(\tan \phi + \tan \alpha)]$, where T = torque at handle, R = mean radius of screw threads, ϕ = angle of friction (approx. 0.1), α = mean pitch angle of screw, and e = efficiency of screw generally about 0.8).

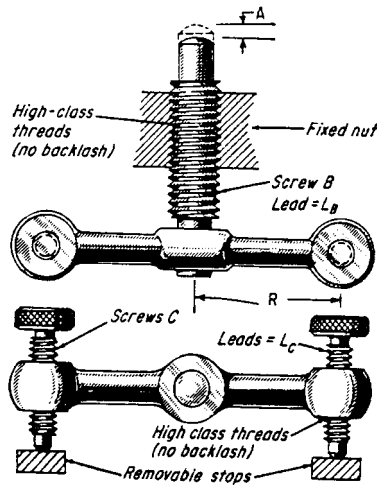

Extremely small movements. Microscopic measurements, for example, are characteristic of this arrangement. Movement A is equal to $N(L_B \times L_C)12\pi R$, where N equals the number of turns of screw C .

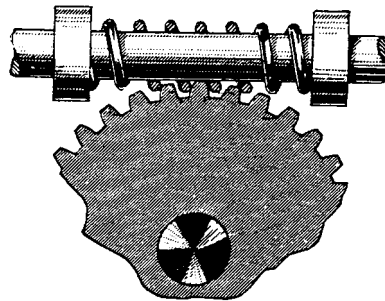

Shock absorber screw. When the springs coiled as shown are used as worm drives for light loads, they have the advantage of being able to absorb heavy shocks.

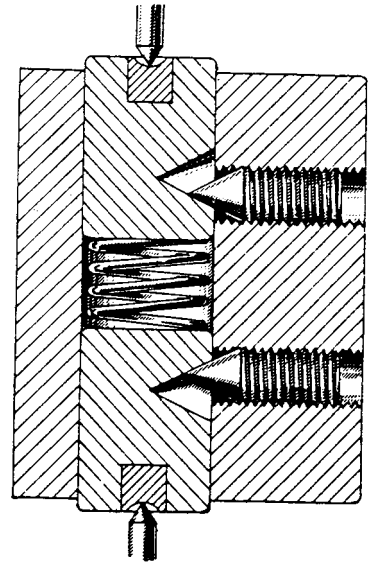

Bearing adjustment. This screw arrangement is a handy way for providing bearing adjustment and overload protection.

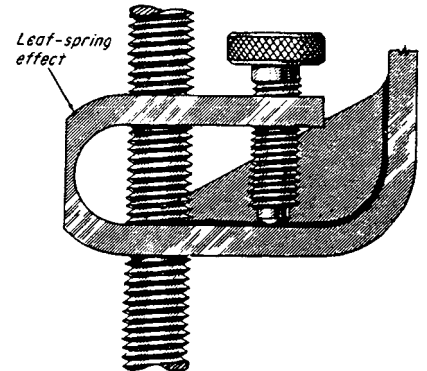

Backlash elimination. The large screw is locked and all backlash is eliminated when the knurled screw is tightened; finger torque is sufficient.

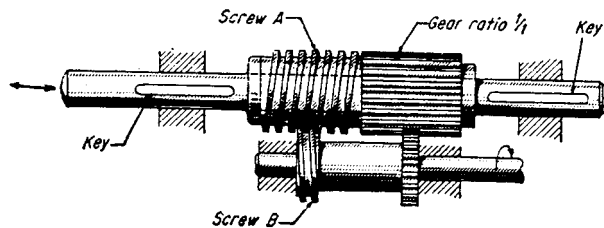

High reduction of rotary motion to fine linear motion is possible here. This arrangement is for low forces. Screws are left and right hand. $L_A = L_B$ plus or minus a small increment. When $L_B = 1/10$ and $L_A = 1/10.5$, the linear motion of screw A will be 0.05 in. per turn. When screws are the same hand, linear motion equals $L_A + L_B$.

FOURTEEN ADJUSTING DEVICES

Here is a selection of some basic devices that provide and hold mechanical adjustment.

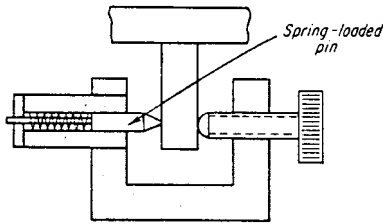

Fig. 1 A spring-loaded pin supplies a counterforce against which an adjustment force must always act. A leveling foot would work against gravity, but for most other setups a spring is needed to give a counter-force.

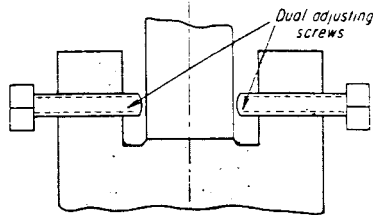

Fig. 2 Dual screws provide an inelastic counterforce. Backing-off one screw and tightening the other allows extremely small adjustments to be made. Also, once adjusted, the position remains solid against any forces tending to move the device out of adjustment.

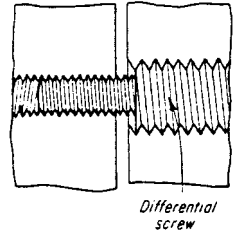
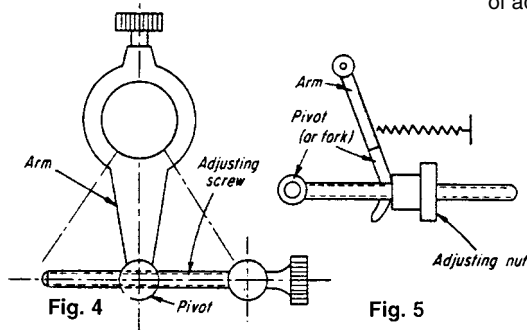

Fig. 3 A differential screw has same-hand threads but with different pitches. The relative distance between the two components can be adjusted with high precision by differential screws.



Figs. 4 and 5 Swivel motion is necessary in (Fig. 4) between the adjusting screw and arm because of a circular locus of female threads in the actuated member. Similar action (Fig. 5) requires either the screw to be pivoted or the arm to be forked.

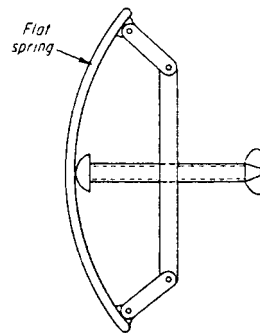

Fig. 6 This arc-drafting guide is an example of an adjusting device. One of its components, the flat spring, both supplies the counterforce and performs the mechanism's main function—guiding the pencil.

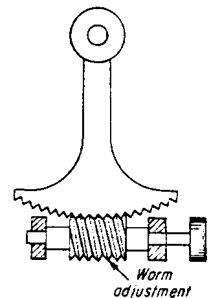

Fig. 7 The worm adjustment shown here is in a device for varying the position of an arm. Measuring instruments, and other tools requiring fine adjustments, include this adjusting device.

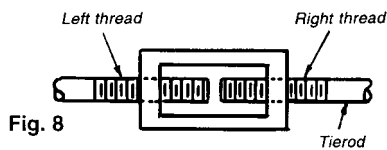

Fig. 8

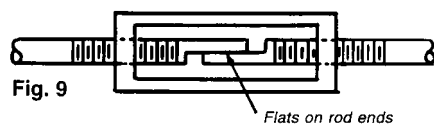

Fig. 9

Figs. 8 and 9 Tierods with opposite-hand threads at their ends (Fig. 8) require only a similarly threaded nut to provide simple, axial adjustment. Flats on the rod ends (Fig. 9) make it unnecessary to restrain both the rods against rotation when the adjusting screw is turned; restraining one rod is enough.

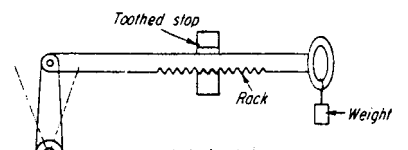

Fig. 13

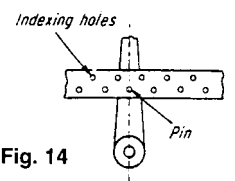

Fig. 14

Figs 13 and 14 Rack and toothed stops (Fig. 13) are frequently used to adjust heavy louvers, boiler doors and similar equipment. The adjustment is not continuous; it depends on the rack pitch. Large counter-adjustment forces might require a weighted rack to prevent tooth disengagement. Indexing holes (Fig. 14) provide a similar adjustment to the rack. The pin locks the members together.

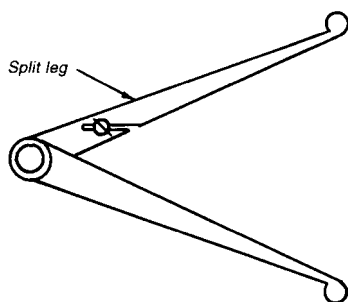

Fig. 10 A split-leg caliper is an example of a simple but highly efficient adjusting device. A tapered screw forces the split leg part, thus enlarging the opening between the two legs.

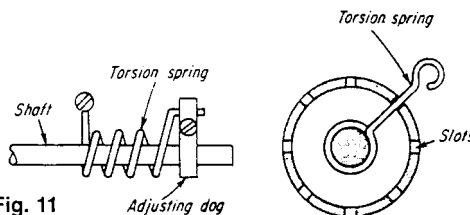

Fig. 11

Fig. 12

Figs. 11 and 12 Shaft torque is adjusted (Fig. 11) by rotating the spring-holding collar relative to the shaft, and locking the collar at a position of desired torque. Adjusting slots (Fig. 12) accommodate the torsion-spring arm after the spring is wound to the desired torque.

LINEAR ROLLER BEARINGS ARE SUITED FOR HIGH-LOAD, HEAVY-DUTY TASKS

The patented Roundway linear roller bearings from Thomson Industries, Inc., Port Washington, NY, can carry heavy loads on supported parallel cylindrical rails where rigidity and stiffness is required. The Roundway linear roller bearing consists of a cylindrical inner bearing race with rounded-ends that is fastened to a mounting block by a trunnion pin. It is enclosed by a linked chain of concave rollers that circulate around the race. The rollers and the inner race are made from hardened and ground high-carbon bearing steel, and the mounting block is cast from malleable iron. The load on the mounting block is transferred through the trunnion pin, race, and roller chain assembly to the supporting rail, which functions as the external raceway.

The height of the bearing can be adjusted with the eccentric trunnion pin to compensate for variations in the mounting sur-

faces. The pin can also be used to preload the bearing by eliminating internal bearing clearance. After the trunnion pin has been adjusted, it can be held in place by tightening the lock screw.

Because a single Roundway linear roller bearing does not resist side loads, a dual version of the Roundway bearing capable of resisting those loads is available. It has two race and roller assemblies mounted on a wider iron block so that the bearings contact the raceway support at angles of 45° from the centerline. In typical motion control installation, two single-bearing units are mounted in tandem on one of the parallel rails and two dual-bearing units are mounted in tandem on the other rail to withstand any side loads.

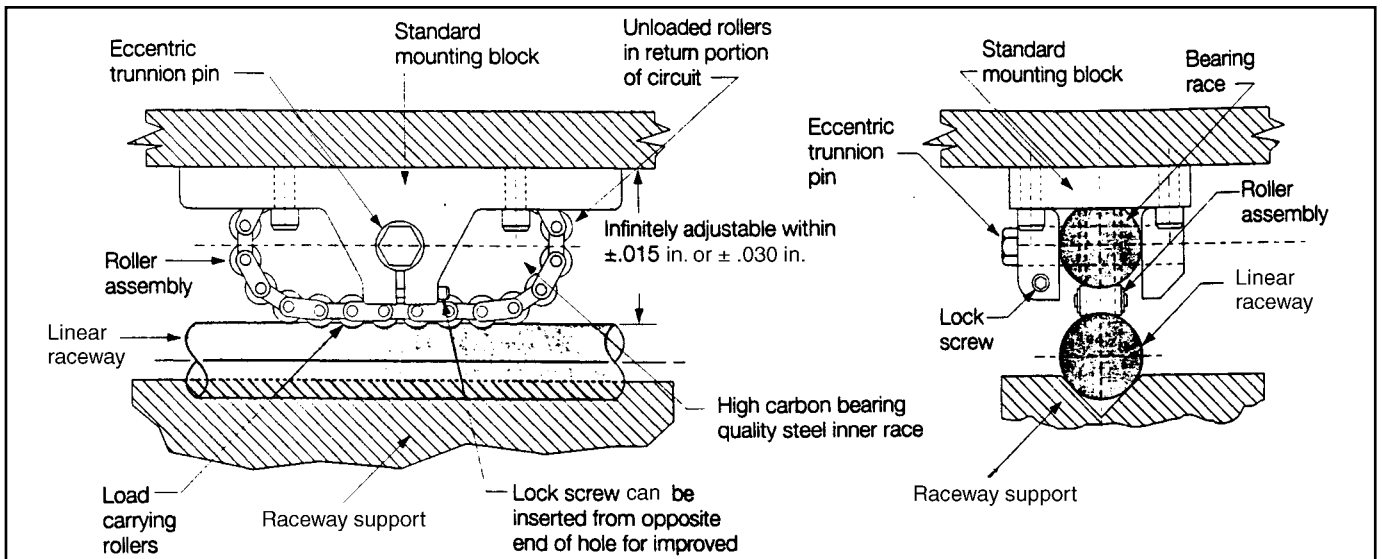

The concave steel rollers in this linear bearing are linked in a chain assembly as they circulate around the inner race.